

» Issue 12

The Handling Equipment Shop



All our products have a full 12 months ON SITE parts & labour warranty

» **The premier name in materials handling...**

The Handling Equipment Shop

Welcome to the latest issue of the Handling Equipment Shop. » The premier name in materials handling...

In this issue you will see our latest **WARRIOR** products. Increased derivatives on hand pallet trucks and lift tables give you even more opportunity to solve those materials handling applications. We have audited all of our suppliers and can guarantee that all the **WARRIOR** products are of high quality and value for money.

We now also have the ability to manufacture “bespoke” handling equipment. If you have the opportunity, give us a call, we’ll help you offer a “bespoke” solution.

Try us for

- ▶ **WARRIOR** Hand Pallet Trucks
- ▶ **WARRIOR** High Lift Pallet Trucks
- ▶ **WARRIOR** Stainless and Galvanised Trucks
- ▶ **WARRIOR** Platform Trucks
- ▶ **WARRIOR** Scissors Lift Tables Mobile and Static up to 8000 kg
- ▶ **WARRIOR** Manual Stackers
- ▶ **WARRIOR** Work Positioners
- ▶ **WARRIOR** Reel Positioners
- ▶ **WARRIOR** Powered Pallet Trucks
- ▶ **WARRIOR** Powered Stackers
- ▶ **WARRIOR** plus Powered Stackers
- ▶ **WARRIOR** Drum Handling
- ▶ **WARRIOR** Load Movers
- ▶ **WARRIOR** plus “SPECIALS”
- ▶ **MARIOTTI** Micro Forklift
- ▶ **ARTISON** Forklift Trucks
- ▶ **WARRIOR EP** Forklift Trucks

As we specialise in TRADE SUPPLY we also offer our commitment to:

- ▶ Many trucks are ex stock
- ▶ Delivered prices
- ▶ Full ON SITE warranty
- ▶ UK Mainland only
- ▶ No quibble 7 day return
- ▶ Fully compliant with European & ISO directives
- ▶ Certificates of conformity
- ▶ 90% spare parts are off the shelf
- ▶ Volume discounts off trade prices

All of our equipment meets EU/UK/ISO standards

Pallet Trucks

WARRIOR WR25 Hand Pallet Truck

2500kg

Various colours available in most models



WARRIOR Eco Warrior

2500kg

Single rollers 1150 x 520mm



3000kg

Various colours available in most models



WARRIOR Easy Roller

ECO WARRIOR 2000kg

FORK DIMENSIONS MODEL NUMBER
1150mm x 540mm Nylon WREZ20S115PTP



Scan for Video

- ▶ Longlife Nylon or Polyurethane rollers
- ▶ Longlife Nylon or polyurethane steer wheels
- ▶ 3 position trigger
- ▶ Full bushing in key areas
- ▶ Greasing points
- ▶ Overload/Pressure relief valve
- ▶ Sealed Bearings
- ▶ Self Lubricating bushes
- ▶ Sealed Hydraulics
- ▶ Exit/Entry rollers
- ▶ Lowered Fork Height - 85mm
- ▶ Raised Fork Height - 200mm
- ▶ Individual Fork Dimensions - 160 x 50mm
- ▶ Steering Wheel Dimensions - 200 x 50mm
- ▶ TNN = Tandem Roller Dimensions 80 x 70mm
- ▶ SNN = Single Roller Dimensions 80 x 93mm

WARRIOR WR25 Hand Pallet Truck		2500kg
FORK DIMENSIONS	MODEL NUMBER	
800mm x 450mm	WR25VS80	
900mm x 450mm	WR25VS90	
1000mm x 540mm	WR25S100	
1150mm x 540mm	WR25S115	
1000mm x 685mm	WR25L100	
1150mm x 685mm	WR25L115	
1220mm x 540mm	WR25S122	
1220mm x 685mm	WR25L122	
Tandem or Single Load Rollers Nylon or Polyurethane		

WARRIOR WR30 Hand Pallet Truck		3000kg
FORK DIMENSIONS	MODEL NUMBER	
1150mm x 540mm Nylon	WR30S115TNN	
1150mm x 685mm Nylon	WR30L115TNN	

WARRIOR CE

Manually assisted self propelled pallet truck

12 MONTHS WARRANTY

All our products have a full 12 months ON SITE parts & labour warranty

Pallet Trucks

WARRIOR EXTRA LONG Pallet Truck

- ▶ Long life tandem nylon rollers & steer wheels as standard
- ▶ Satisfy non standard pallet and load handling applications
- ▶ Climber wheels
- ▶ 3 position trigger
- ▶ Full bushing in key areas
- ▶ Greasing points
- ▶ Overload/pressure relief valve; self lubricating brushes
- ▶ Sealed hydraulics;
- ▶ Exit/entry rollers

WARRIOR CE



MODEL	BRAND	CAPACITY	FORK DIMENSIONS	RAISED FORK HEIGHT	LOWERED FORK HEIGHT	STEERING WHEEL DIMENSIONS	TANDEM ROLLER DIMENSIONS
WRL20LEELFTNN	Warrior	2000kg	2000mm x 685mm	200mm	85mm	200 x 50mm	80 x 70mm
WRL20LNQEELFTNN	Warrior	2000kg	1800mm x 685mm	200mm	85mm	200 x 50mm	80 x 70mm
WRL20LELFTNN	Warrior	2000kg	1500mm x 685mm	200mm	85mm	200 x 50mm	80 x 70mm
WRL20SEELFTNN	Warrior	2000kg	2000mm x 540mm	200mm	85mm	200 x 50mm	80 x 70mm
WRL20SNQEELFTNN	Warrior	2000kg	1800mm x 540mm	200mm	85mm	200 x 50mm	80 x 70mm
WRL20SELFTNN	Warrior	2000kg	1500mm x 540mm	200mm	85mm	200 x 50mm	80 x 70mm
WRL35LEELFTNN	Warrior	3500kg	2500mm x 685mm	200mm	85mm	200 x 50mm	80 x 70mm
WRL35LNQEELFTNN	Warrior	3500kg	2000mm x 685mm	200mm	85mm	200 x 50mm	80 x 70mm
WRL35SELFTNN	Warrior	3500kg	2500mm x 540mm	200mm	85mm	200 x 50mm	80 x 70mm
WRL35SNQEELFTNN	Warrior	3500kg	2000mm x 540mm	200mm	85mm	200 x 50mm	80 x 70mm

WARRIOR EXTRA WIDE Pallet Truck

- ▶ Long life tandem nylon rollers & steer wheels as standard
- ▶ Satisfy non standard wide loads
- ▶ Durable powder coated mainframe
- ▶ 3 position trigger
- ▶ Full bushing in key areas
- ▶ Greasing points
- ▶ Overload/pressure relief valve; self lubricating brushes
- ▶ Sealed hydraulics
- ▶ Exit/entry rollers

WARRIOR CE



MODEL	BRAND	CAPACITY	FORK DIMENSIONS	RAISED FORK HEIGHT	LOWERED FORK HEIGHT	STEERING WHEEL DIMENSIONS	TANDEM ROLLER DIMENSIONS
WRW20EEWTNN	Warrior	2000kg	1000 x 1220mm	200mm	85mm	200 x 50mm	80 x 70mm
WRW20ELWFTNN	Warrior	2000kg	838 x 1220mm	200mm	85mm	200 x 50mm	80 x 70mm

Pallet Trucks

WARRIOR Rough Terrain Pallet Truck

▶ Capacity	1200kg
▶ Load Centre	450mm
▶ Overall Width	1605mm
▶ Inside Straddle Width	1277mm
▶ Overall Length	1375mm
▶ Overall Height	1200mm
▶ Fork Length	860mm
▶ Adjustable Forks	212 - 735mm
▶ Fork Width	100mm
▶ Lowered Fork Height	63mm
▶ Lift Height	233
▶ Front Load Wheel	Ø 550 x 132mm
▶ Steering Wheel	Ø 265 x 80mm
▶ Weight	225kg



WARRIOR CE

The new **WARRIOR WRTT12** Rough Terrain Pallet Truck is ideal for outdoor applications where a conventional industrial truck just won't do! Mounted on large pneumatic tyred wheels all round, the truck just rides over undulating surfaces you find in some applications. With a capacity of 1200kg and an inside straddle width of 1277mm the **WRTT12** will handle most pallets. Ideal for garden centers, building sites, farmyards and all other rough terrain applications.

WARRIOR Reel/Cylinder Carrier

- ▶ Greasing points
- ▶ Overload/pressure relief valve
- ▶ Ideal for handling paper reels, textile rolls & cable drums
- ▶ Tandem rollers
- ▶ Nylon steer wheels

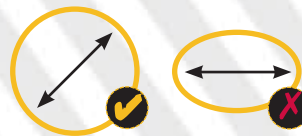

Always check your widest point you may need the next model up

MODEL	BRAND	CAPACITY	FORK DIMENSIONS	REEL DIMENSIONS	WEIGHT
WR20R500	Warrior	2000kg	1220mm x 760mm	400mm - 600mm dia	75kg
WR20R700	Warrior	2000kg	1220mm x 850mm	600mm - 800mm dia	75kg
WR20R1000	Warrior	2000kg	1220mm x 1000mm	800mm - 1200mm dia	75kg
WR20R1500	Warrior	2000kg	1220mm x 1150mm	1200mm - 1600mm dia	75kg

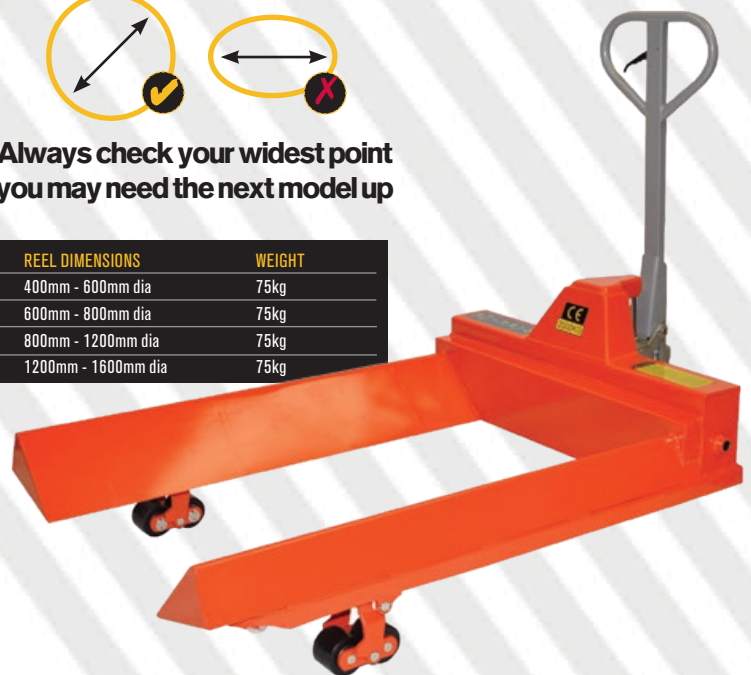

WARRIOR CE

All our products have a full 12 months ON SITE parts & labour warranty

12 MONTHS WARRANTY

Pallet Trucks

WARRIOR LOW PROFILE Hand Pallet Truck

- ▶ Sealed bearings
- ▶ 3 position trigger
- ▶ Ideal for handling crates, American/Japanese pallets
- ▶ Greasing points
- ▶ Overload/pressure relief valve
- ▶ Self lubricating brushes; sealed hydraulics
- ▶ Tandem nylon rollers & nylon steer wheels



WARRIOR CE

MODEL	BRAND	CAPACITY	FORK DIMENSIONS	RAISED FORK HEIGHT	LOWERED FORK DIMENSIONS	INDIVIDUAL FORK DIMENSIONS	STEERING WHEEL DIMENSIONS	LOAD ROLLER DIMENSIONS	WEIGHT
WRLOW51L	Warrior	2000kg	1150 x 685mm	165mm	51mm	160 x 37mm	180 x 50mm	50 x 70mm	75kg
WRLOW51S	Warrior	2000kg	1150 x 540mm	165mm	51mm	160 x 37mm	180 x 50mm	50 x 70mm	75kg

WARRIOR SUPALOW PROFILE Hand Pallet Truck

- ▶ Sealed bearings
- ▶ 3 position trigger
- ▶ Ideal for handling crates, vending machines and appliances
- ▶ Greasing points
- ▶ Overload/pressure relief valve
- ▶ Self lubricating brushes
- ▶ Sealed hydraulics
- ▶ Tandem steel rollers; Polyurethane steer wheels



WARRIOR CE

MODEL	BRAND	CAPACITY	FORK DIMENSIONS	RAISED FORK HEIGHT	LOWERED FORK DIMENSIONS	INDIVIDUAL FORK DIMENSIONS	STEERING WHEEL DIMENSIONS	LOAD ROLLER DIMENSIONS	WEIGHT
WRLOW35L	Warrior	1000kg	1120 x 685mm	90mm	35mm	160 x 30mm	160 x 50mm	34 x 58mm	75kg
WRLOW35S	Warrior	1000kg	1120 x 540mm	90mm	35mm	160 x 30mm	160 x 50mm	34 x 58mm	75kg

Pallet Trucks

WARRIOR WEIGH SCALE Pallet Truck

- ▶ 1kg Increments
- ▶ Accuracy +/- 0.1%
- ▶ Large Click Quality Fascia
- ▶ Polyurethane wheels/rollers to reduce vibration
- ▶ Totalising function; high contrast display
- ▶ High battery autonomy with 70 hours of use
- ▶ Water and dust proof to norm IP65
- ▶ Optional built-in thermal printer



MODEL	BRAND	CAPACITY	FORK DIMENSIONS	RAISED FORK HEIGHT	LOWERED FORK HEIGHT	INDIVIDUAL FORK DIMENSIONS	STEERING WHEEL DIMENSIONS	TANDEM ROLLER DIMENSIONS	WEIGHT
WRESR20S	Warrior	2000kg	1150 x 572mm	200mm	85mm	180mm x 50mm	180mm x 50mm	74mm x 70mm	75kg
WRESR20L	Warrior	2000kg	1220 x 692mm	200mm	85mm	180mm x 50mm	180mm x 50mm	64mm x 70mm	75kg

Printer option - Sturdy Thermal Printer with low power consumption.

- ▶ WRESR20SPR Please Call
- ▶ WRESR20LPR Please Call



WARRIOR CE

All our products have a full 12 months ON SITE parts & labour warranty



Pallet Trucks

WARRIOR Weigh Scale Pallet Truck

WARRIOR CE

The **WARRIOR** economy Weigh Scale Hand Pallet Truck is an excellent economic solution for weighing pallets with a capacity of up to 2000kg

- ▶ 2000 kg maximum load capacity
- ▶ Graduation in 5kg
- ▶ Fork dimensions 1150mm x 540mm
- ▶ Rubber Tyred steer wheels / Polyurethane tandem rollers to reduce vibration
- ▶ Accuracy 0 - 500kg = +/- 10kg
- ▶ Accuracy 500 - 1000kg = +/- 20kg
- ▶ Accuracy 1000 - 2000kg = +/- 30kg
- ▶ Zero function
- ▶ Total weight function
- ▶ High contrast display
- ▶ High battery autonomy with 3000 weighings per set of batteries
- ▶ Splash proof to norm IP65
- ▶ Batteries 2 x 1.5volt AA non rechargeable
- ▶ Operating temperature minus 10 to plus 40 Celsius
- ▶ Auto shut off after 2 minutes
- ▶ Tandem polyurethane load rollers
- ▶ Polyurethane tyred steer wheels



WRESE20S115TPP



WARRIOR Workhorse Pallet Truck

- ▶ Sealed bearings
- ▶ 3 position trigger
- ▶ Full bushing in key areas
- ▶ Greasing points
- ▶ Overload/pressure relief valve
- ▶ Self lubricating brushes
- ▶ Sealed hydraulics
- ▶ Exit/entry rollers

MODEL	WR50S
Brand	Warrior
Capacity	5000kg
Fork Dimensions	1150mm x 580mm
Raised Fork Height	200mm
Lowered Fork Height	90mm
Individual Fork Width	210mm
Steering Wheel Dimensions	200 x 50mm
Load Roller Dimensions	80 x 68mm
Weight	140kg



Pallet Trucks

WARRIOR Galvanised Semi-Stainless Steel Pallet Truck

- ▶ Capacity 2000kg
- ▶ 2 sizes
- ▶ Chrome plated hydraulic lift ram and valve
- ▶ Fully galvanised mainframe and forks
- ▶ Fully sealed hydraulic nickel coated pump (i.e no atmosphere contaminates in hydraulics)

MODEL	BRAND	CAPACITY	FORK LENGTH	FORK OVERALL WIDTH	LOWERED FORK HEIGHT	RAISED FORK HEIGHT	INDIVIDUAL FORK DIMENSIONS	STEERING WHEEL DIMENSIONS	LOAD ROLLER DIMENSIONS	WEIGHT
WRZ20HS115TNN	Warrior	2000kg	1150mm	540mm	85mm	200mm	160 x 60mm	Ø 200x50mm	Ø 80x70mm	75kg
WRZ20HL115TNN	Warrior	2000kg	1150mm	685mm	85mm	200mm	160 x 60mm	Ø 200x50mm	Ø 80x70mm	75kg

WARRIOR CE



316 Stainless

WARRIOR Stainless Steel Pallet Truck

- ▶ Capacity 2000kg
- ▶ 2 sizes
- ▶ Chrome plated hydraulic lift ram and valve
- ▶ Stainless mainframe, pump, handle, bearings, pins, chains, etc.
- ▶ Fully sealed hydraulic nickel coated pump (i.e no atmosphere contaminates in hydraulics) For use with pharmaceutical, foods, saline, alkaline, acidic and other aggressive environments

MODEL	BRAND	CAPACITY	FORK LENGTH	FORK OVERALL WIDTH	LOWERED FORK HEIGHT	RAISED FORK HEIGHT	INDIVIDUAL FORK DIMENSIONS	STEERING WHEEL DIMENSIONS	LOAD ROLLER DIMENSIONS	WEIGHT
WRS20S115TNN	Warrior	2000kg	1150mm	540mm	85mm	200mm	160 x 60mm	Ø 200x50mm	Ø 80x70mm	82kg
WRS20L115TNN	Warrior	2000kg	1150mm	685mm	85mm	200mm	160 x 60mm	Ø 200x50mm	Ø 80x70mm	82kg

WARRIOR CE



All our products have a full 12 months ON SITE parts & labour warranty

12 MONTHS WARRANTY

High Lift Pallet Trucks

WARRIOR Manual High Lift Pallet

HEAVY DUTY

- ▶ Quicklift below 250kg
- ▶ Adjustable stabilisers
- ▶ Ideal for use with an open bottom pallet
- ▶ Helps reduce repetitive strain back injury
- ▶ Useful at the end of production lines and to use as a work bench
- ▶ Overload/pressure relief valve; self lubricating brushes
- ▶ Sealed hydraulics system
- ▶ Single nylon rollers



WARRIOR high lift pallet trucks are for use with an open bottom pallet and through their design, help to reduce repetitive strain back injury that can occur when bending down unloading a pallet.

They are extremely useful at the end of production lines and to use as a work bench.

MODEL	BRAND	CAPACITY	FORK DIMENSIONS	RAISED FORK HEIGHT	LOWERED FORK HEIGHT	INDIVIDUAL FORK DIMENSIONS	STEERING WHEEL DIMENSIONS	FORK ROLLER DIMENSIONS	WEIGHT
WR10540	Warrior	1000kg	1170 x 540mm	800mm	85mm	160 x 50mm	180 x 50mm	75 x 50mm	75kg
WR10680	Warrior	1000kg	1170 x 685mm	800mm	85mm	160 x 50mm	180 x 50mm	75 x 50mm	75kg
WR15540	Warrior	1500kg	1150 x 540mm	800mm	85mm	160 x 50mm	180 x 50mm	75 x 50mm	75kg
WR15680	Warrior	1500kg	1150 x 680mm	800mm	85mm	160 x 50mm	180 x 50mm	75 x 50mm	75kg

WARRIOR Electric High Lift Pallet Truck

- ▶ Greasing points
- ▶ Ideal for use with an open bottom pallet
- ▶ Helps reduce repetitive strain back injury
- ▶ Useful at the end of production lines and to use as a work bench
- ▶ Overload/pressure relief valve, self lubricating brushes
- ▶ Sealed hydraulics system
- ▶ Single nylon rollers

Manual and Electric lift / lower for precise positioning



All **WARRIOR** High Lift Pallet Trucks will work happily with open bottomed pallets eg europallets and stillages. They will not work with "Full Perimeter Board" Pallets. Scissor pallet trucks aid manual handling and are a useful truck to have around any factory.

MODEL	BRAND	CAPACITY	FORK DIMENSIONS	RAISED FORK HEIGHT	LOWERED FORK HEIGHT	INDIVIDUAL FORK DIMENSIONS	STEERING WHEEL DIMENSIONS	FORK ROLLER DIMENSIONS	BATTERY	LIFTING MOTOR	WEIGHT
WRACX-10E	Warrior	1000kg	1170 x 540mm	800mm	85mm	160 x 50mm	180 x 50mm	75 x 50mm	12V/60Ah	0.8kw	169kg
WRACX-10EW	Warrior	1000kg	1170 x 680mm	800mm	85mm	160 x 50mm	180 x 50mm	75 x 50mm	12V/60Ah	0.8kw	169kg

High Lift Pallet Trucks

WARRIOR Galvanized High Lift Pallet Truck

- ▶ Ideal for aggressive environment food production lines and wet areas
- ▶ Full galvanised mainframe and forks
- ▶ No paint to flake and no bare rust patches to contaminate

WARRIOR CE



MODEL	BRAND	CAPACITY	LIFT HEIGHT	LOWERED HEIGHT	FORK DIMENSIONS	INDIVIDUAL FORK DIMENSIONS	STEERING WHEEL DIMENSIONS	FORK ROLLER DIMENSIONS	WEIGHT
WRHG540M	Warrior	1000kg	800mm	85mm	1165 x 540mm	160 x 50mm	200 x 50mm	78 x 60mm	116kg
WRHG680M	Warrior	1000kg	800mm	85mm	1165 x 540mm	160 x 50mm	200 x 50mm	78 x 60mm	126kg

WARRIOR 316 Stainless Steel High Lift Pallet Truck

- ▶ Ideal for aggressive environment food production lines and wet areas
- ▶ Full galvanised mainframe and forks
- ▶ No paint to flake and no bare rust patches to contaminate

WARRIOR CE



MODEL	BRAND	CAPACITY	FORK DIMENSIONS	INDIVIDUAL FORK DIMENSIONS	FORK ROLLER	STEER WHEEL	BATTERY
WRHS540M	Warrior	1000kg	1165 x 540mm	160 x 50mm	Ø78 x 60mm	Ø200 x 50mm	
WRHS680M	Warrior	1000kg	1165 x 680mm	160 x 50mm	Ø78 x 60mm	Ø200 x 50mm	
WRHS540E	Warrior	1000kg	1165 x 540mm	160 x 50mm	Ø78 x 60mm	Ø200 x 50mm	12v - 54Ah
WRHS680E	Warrior	1000kg	1165 x 680mm	160 x 50mm	Ø78 x 60mm	Ø200 x 50mm	12v - 54Ah

All our products have a full 12 months ON SITE parts & labour warranty

12 MONTHS WARRANTY

Powered Pallet Trucks

WARRIOR WREPT12-EZ Full Electric Pallet Truck



NEW

- ▶ Fully powered drive/lift and same size as a manual pallet truck
- ▶ Easy to use
- ▶ 100% charge in 2.5 hours - 50% charge in 30 minutes
- ▶ Ergonomically design with reduced noise
- ▶ Battery discharge indicator
- ▶ E Stop
- ▶ The future of pallet trucks!

WARRIOR CE

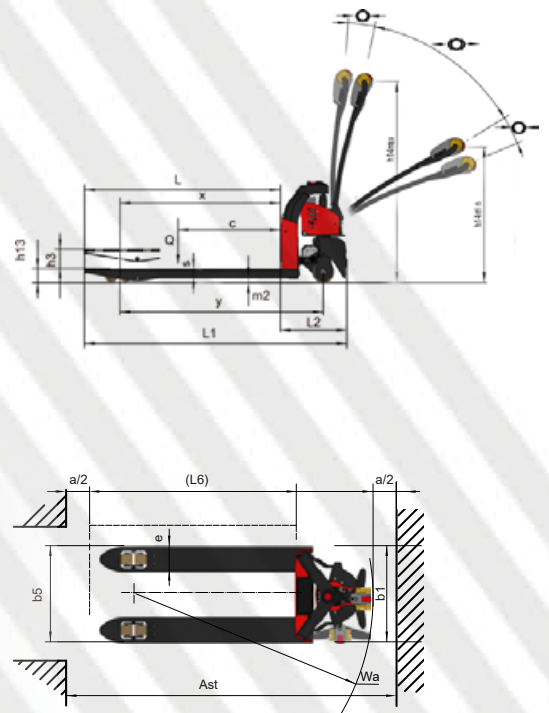

1200 Kg



Powered Pallet Trucks

The Handling Equipment Shop

The premier name in materials handling...

	MODEL			WREPT12-EZ
Characteristics	1.2 Manufacturer			Warrior
	1.3 Power unit			Battery
	1.4 Operator type			Pedestrian
	1.5 Lowering type			Manual
	1.6 Load capacity	Q	kg	1200
	1.7 Load centre	c	mm	600
	1.8 Axle centre to fork face	x	mm	950
	1.9 Wheelbase	y	mm	1190
	2.1 Service weight (include battery)		kg	120
Weights	2.2 Axle loading with load, driving side/loading side		kg	410/910
	2.3 Axle loading without load, driving side/loading side		kg	100/20
	3.1 Tyre type driving wheels/loading wheels			PU/PU
Wheels /tyres	3.2 Tyre size, driving wheels (diameter × width)		mm	Ø130 x 55
	3.3 Tyre size, loading wheels (diameter × width)		mm	Ø80 x 60
	3.4 Wheels, number driving/loading (x=drive wheels)		mm	1 x +2/4
	4.4 Lift height	h_3	mm	115
Dimensions	4.9 Height of tiller arm in driving position, min./max.	h_{14}	mm	800/1170
	4.15 fork height, lowered	h_3	mm	80
	4.19 Overall length	l_1	mm	1540
	4.20 Length to fork face	l_2	mm	390
	4.21 Overall width	b_1	mm	560
	4.22 Fork dimensions	sxex	mm	53 x 150 x 1150
	4.25 Distance between forks	b_5	mm	240
	4.32 Ground clearance, center of wheelbase	m_2	mm	27
	4.33 Aisle width for pallets 1000 × 1200 crossways	Ast	mm	1640
	4.34 Aisle width for pallets 800 × 1200 lengthways	Ast	mm	1840
	4.35 Turning radius	Wa	mm	1390
Performance	5.1 Travel speed, with/without load		km/h	3.8/4
	5.2 Lifting speed, with/without load		m/s	0.02/0.025
	5.3 Lowering speed, with/without load		m/s	0.06/0.03
	5.8 Max. gradeability, with/without load		%	2/8
	5.10 Service brake			electric
Drive	6.1 Drive motor rating 60 min		kW	0.45
	6.2 Lift motor rating at 15%		kW	0.5
	6.3 Battery Type			Li-ion
	6.4 Battery voltage/rated capacity (5h)		V/Ah	24/20
	6.5 Battery weight		kg	3.7
	6.6 Power consumption according to VDI cycle		KW/h	0.16
Others	8.1 Type of drive control			DC
	8.4 Noise at the driver's ear			<74

1. The parameters in the table are of the standard model. For more information please contact us.
2. The parameters are subject to change without notice.

All our products have a full 12 months ON SITE parts & labour warranty

12 MONTHS WARRANTY

Powered Pallet Trucks

WARRIOR EPT20-15ET Full Electric Pallet Truck

- ▶ Compact Size & Light Weight, Convenient for Operation
- ▶ Energy-saving & environment-friendly design maximizes running time
- ▶ Can replace drive wheel only by releasing six nuts
- ▶ Alternative sizes to order please call
- ▶ Easy to replace drive wheel (10 minutes)
- ▶ Weigh scale option available



WARRIOR CE

NEW

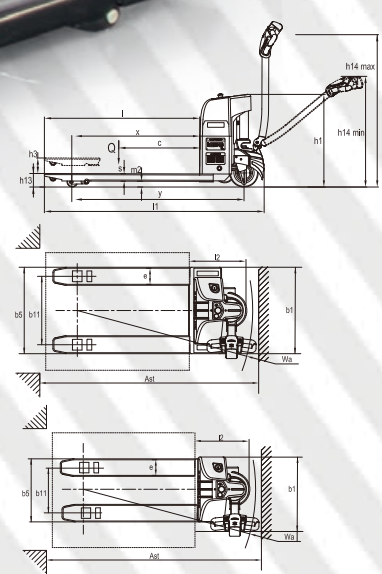

Powered Pallet Trucks

The Handling Equipment Shop

The premier name in materials handling...

	MODEL			EPT20-15ET
Distinguishing mark	1.1 Manufacturer			Warrior
	1.2 Model designation			EPT20-15ET
	1.4 Driver unit			Electric
	1.5 Type of operation			Pedestrian
	1.6 Rated capacity	Q	kg	1500
	1.7 Load centre distance	c	mm	600
	1.8 Load distance	x	mm	889/946
	1.9 Wheelbase	y	mm	1268/1231
	Weight	2.1 Service weight (include battery)		kg
2.2 Axle loading with load, driving side/loading side			kg	550/1155
2.3 Axle loading without load, driving side/loading side			kg	180/25
Types/Chassis	3.1 Tyre type driving wheels/loading wheels			PU/PU
	3.2 Tyre size, driving wheels (diameter × width)		mm	Ø210 x 70
	3.3 Tyre size, loading wheels (diameter × width)		mm	2 x Ø80 x 60
	3.4 Tyre size, caster wheels (diameter × width)		mm	/
	3.5 Wheels, number driving/loading (x=drive wheels)		mm	1 x /4
	3.6 Track width, front, driving side	b ₁₀	mm	/
	3.7 Track width, rear, loading side	b ₁₁	mm	410
Dimensions	4.4 Lift height	h ₃	mm	115
	4.9 Height drawbar in driving position min./max.	h ₁₄	mm	750/1170
	4.15 Lowered height	h ₁₃	mm	85
	4.19 Overall length	l ₁	mm	1632
	4.20 Length to fork face	l ₂	mm	482
	4.21 Overall width	b ₁ /b ₂	mm	560
	4.22 Fork dimensions	s/e/l	mm	50/150/1150
	4.25 Distance between forks	b ₅	mm	240
	4.32 Ground clearance, center of wheelbase	m ₂	mm	35
	4.34.1 Aisle width for pallets 1000 × 1200 crossways	Ast	mm	1739
	4.34.2 Aisle width for pallets 800 × 1200 lengthways	Ast	mm	1939
4.35 Turning radius	Wa	mm	1485	
Performance	5.1 Travel speed, laden/ unladen	km/h	km/h	4/4.5
	5.2 Lifting speed, laden/ unladen		m/s	0.026/0.031
	5.3 Lowering speed, laden/ unladen		m/s	0.029/0.021
	5.8 Max. gradeability, laden/unladen			2/6
	5.10 Service brake type			Electromagnetic
Electric/engine	6.1 Drive motor rating S2 60 min		kW	0.85
	6.2 Lift motor rating at S3 15%		kW	0.84
	6.3 The maximum allowed size battery		mm	265*185*215
	6.4 Battery voltage/nominal capacity 1<20			24/85
	6.5 Battery weight		kg	25.5x2
Others	8.1 Type of drive control			DC
	8.4 Steering type			Mechanical
	8.4 Sound pressure level at the driver's ear			<74

1. The parameters in the table are of the standard model. For more information please contact us.
2. The parameters are subject to change without notice.

All our products have a full 12 months ON SITE parts & labour warranty

12 MONTHS WARRANTY

Powered Pallet Trucks

WARRIOR WREPT-20WA Full Electric Heavy Duty Pallet Truck



- ▶ Powered drive & elevation
- ▶ Ergonomic design of front chassis & bottom frame
- ▶ Ergonomical tiller head
- ▶ Suitable for all popular pallets
- ▶ Creep speed function & switch, zapf control box
- ▶ Emergency anti pin switch & anti-roll braking system
- ▶ Battery discharge indicator
- ▶ AC system & AMP connector

WARRIOR CE

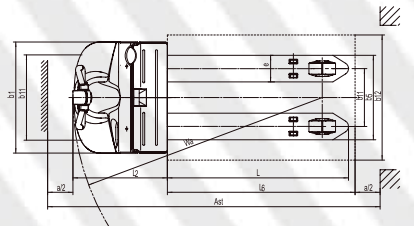
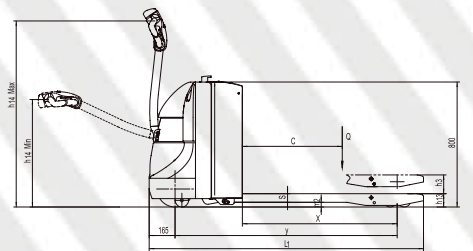

Powered Pallet Trucks

The Handling Equipment Shop

The premier name in materials handling...

	MODEL			WREPT20-20WA	
Characteristics	1.1	Manufacturer		Warrior	
	1.2	Model designation		Electric	
	1.3	Drive unit		Pedestrian	
	1.4	Type of operation		Manual	
	1.5	Rated capacity	Q	kg	2000
	1.7	Load centre distance	c	mm	600
	1.8	Load distance	x	mm	916/982 937/1003
	1.9	Wheelbase	y	mm	1418 1488
	Weights	2.1	Service weight (include battery)		kg
2.2		Axle loading, laden driving side/loading side		kg	955/1580
2.3		Axle loading, unladen driving side/loading side		kg	430/105
Wheels/tyres	3.1	Tyre type driving wheels/loading wheels		mm	PU/PU
	3.2	Tyre size, driving wheels (diameter × width)			Ø230 x 75
	3.3	Tyre size, loading wheels (diameter × width)		mm	Ø85 x 70 Ø83 x 115
	3.4	Tyre size, caster wheels (diameter × width)		mm	Ø85 x 48
	3.5	Wheels, number driving, caster/loading (x=drive wheels)		mm	1 x +2/4 1 x +2/2
	3.6	Track width, front, loading side	b ₁₀	mm	498
	3.7	Track width, rear, loading side	b ₁₁	mm	370/430/515
Dimensions	4.4	Lift height	h ₃	mm	120
	4.9	Height drawbar in driving position, min./max.	h ₁₄	mm	715/1200
	4.15	Lowered height	h ₃	mm	85
	4.19	Overall length	l ₁	mm	1748 1818
	4.20	Length to fork face	l ₂	mm	598
	4.21	Overall width	b ₁	mm	710
	4.22	Fork dimensions	s/e/l	mm	55 x 170 x 1150 55 x 170 x 1220
	4.25	Distance overall forks	b ₅	mm	540/685
	4.32	Ground clearance, center of wheelbase	m ₂	mm	30
	4.34.1	Aisle width for pallets 1000 × 1200 crossways	Ast	mm	1815
	4.34.2	Aisle width for pallets 800 × 1200 lengthways	Ast	mm	2015
4.35	Turning radius	Wa	mm	1595	
Performance	5.1	Travel speed, laden/unladen		km/h	5/5.5
	5.2	Lifting speed, laden/unladen		m/s	0.02/0.025
	5.3	Lowering speed, laden/unladen		m/s	0.06/0.03
	5.8	Max. gradeability, laden/unladen		%	2/8
	5.10	Service brake			electric
Drive	6.1	Drive motor rating S2 60 min		kW	1.1
	6.2	Lift motor rating at S3 15%		kW	0.84
	6.3	The maximum allowed size battery			680 x 205 x 600
	6.4	Battery voltage/nominal capacity KS		V/Ah	24/210
	6.5	Battery weight		kg	190
Others	8.1	Type of drive control			AC
	8.1	Steering type			Mechanical
	8.4	Sound pressure level at the driver's ear			<74

1. The parameters in the table are of the standard model. For more information please contact us.
2. The parameters are subject to change without notice.

All our products have a full 12 months ON SITE parts & labour warranty

12 MONTHS WARRANTY

Work Positioners/Stackers

WARRIOR Work Positioners M200 & E100A

- ▶ Compact, lightweight & manoeuvrable
- ▶ Self sustaining winch
- ▶ Auto brake system to prevent uncontrolled lowering
- ▶ Mounted on 4 swivel castors



- 1 V Block
- 2 Double Spindle (E100A)
- 3 Reel Rotator (E100A)



MODEL	BRAND	CAPACITY	LOAD CENTRE	MIN HEIGHT	MAX HEIGHT	PLATFORM SIZE	LOAD WHEEL	STEERING WHEEL	OVERALL DIMENSIONS L x W x H
WRM200	Warrior	200kg	235mm	130mm	1500mm	470 x 600mm	Ø 75mm	Ø 125mm	870 x 600 x 1920mm
E100A	Warrior	100kg	235mm	130mm	1700mm	470 x 600mm	Ø 75mm	Ø 125mm	870 x 600 x 1790mm

WARRIOR Work Positioner MES150

Battery operated work positioner ideal for handling small loads in shops, stores etc. Equipped with 4 polyurethane swivel castors (2 braked). Supplied complete with battery (12V/7Ah) and charger. CE marked.

MODEL	TYPE	CAPACITY	PLATFORM DIMENSIONS	MAX LIFT	MIN LIFT	OVERALL SIZE L x W x H	FRONT TYRE SIZE	REAR TYRE SIZE
MES150	Electric	150kg	470 x 520mm	1420mm	130mm	880 x 520 x 1950mm	75 x 32mm	100 x 32mm



WARRIOR CE

WARRIOR MiniStacker

Our Ministackers are excellent for the everyday light duty work area where loads to be lifted far exceed "the manual handling directive" but do not demand a heavy duty industrial stacker. With a capacity of 400kg and 3 lift height options the Ministackers are suitable for many internal jobs.

- ▶ Smooth operating foot pump & braked steer wheels
- ▶ Pressure/overload valve
- ▶ Smart chromium plated frame
- ▶ Position lifting
- ▶ Very manoeuvrable

MODEL	BRAND	CAPACITY	PLATFORM HEIGHT MAX	PLATFORM HEIGHT MIN	PLATFORM LENGTH	PLATFORM WIDTH	SIZE OF FORKS	STEERING ROLLER	LOAD ROLLER	WEIGHT
WR0485	Warrior	400kg	850mm	85mm	650mm	576mm	650 x 110mm	Ø 127 x 40mm	Ø 75 x 40mm	75kg
WR0412	Warrior	400kg	1200mm	85mm	650mm	576mm	650 x 110mm	Ø 127 x 40mm	Ø 75 x 40mm	81kg
WR0415	Warrior	400kg	1500mm	85mm	650mm	576mm	650 x 110mm	Ø 127 x 40mm	Ø 75 x 40mm	91kg



Work Positioners

WARRIOR Light Duty Counterbalanced Stacker

- ▶ Counterbalance design giving a general handling capability
- ▶ Capacity 250kg
- ▶ Lightweight and compact design
- ▶ Semi electric with built in charger
- ▶ Ergonomically designed, ideal for indoor use

MODEL	BRAND	CAPACITY	MAX. FORK HEIGHT	MIN. FORK HEIGHT	FORK SIZE HEIGHT	ADJUSTABLE FORK WIDTH	POWER	BATTERY	OVERALL SIZE (L x W x H)	NET WEIGHT
WREZ2515	Warrior	250kg	1200mm	80mm	600 x 100mm	215-550	DC12V/800w	DC12V/60Ah	1500x720x1440	225



WARRIOR Semi Electric MiniStacker

When frequency of lift is part of the equation premium **WARRIOR** Semi Electric Mini Stackers are extremely useful. **WARRIOR** WREMS Ministackers are available in three models at 400kg and 3 lift heights being electro hydraulically raised and lowered. When labour costs need reducing this range of MiniStackers are ideal.

- ▶ Smooth positive efficient operation
- ▶ Light & easy to manoeuvre
- ▶ Smart chromium plated frame
- ▶ Powder coated forks and platform
- ▶ Smooth running braked steering wheels
- ▶ Supplied with forks and platform

MODEL	BRAND	CAPACITY	MIN. FORK HEIGHT	MAX. FORK HEIGHT	POWER UNIT	BATTERY	WEIGHT
WREMS0485	Warrior	400kg	80mm	850mm	0.8kW	Ø12V/80Ah	117kg
WREMS0412	Warrior	400kg	80mm	1200mm	0.8kW	Ø12V/80Ah	122kg
WREMS0415	Warrior	400kg	80mm	1500mm	0.8kW	Ø12V/80Ah	127kg



WARRIOR Winch Stackers

- ▶ Compact and service free design
- ▶ Unique design of winch for easier and safer lifting
- ▶ Heavy duty C section mast
- ▶ Two parking brakes on steer wheels

MODEL	WS50	WS100
Brand	Warrior	Warrior
Capacity	kg 500	1000
Load Centre	mm 500	575
Max. Fork Height	mm 1560	1500
Lowered Fork Height	mm 90	88
Fork Adjustable Width	mm 160 - 690	540 fixed
Fork Width	mm 70	160
Fork Length	mm 1000	1150
Front Load Roller	mm Ø 80 x 47	Ø 80 x 94
Steering Wheel	mm Ø 150 x 40	Ø 150 x 50
Weight	kg 146	182



All our products have a full 12 months ON SITE parts & labour warranty

12 MONTHS WARRANTY

Stackers

WARRIOR Manual Stacker

WARRIOR Manual Stackers are a cost effective way of handling goods. High quality materials and build give these stackers durability and value. Various model options for most applications. **Special designs available.**

- ▶ Pulling handle
- ▶ Brake
- ▶ Steer wheel foot guards
- ▶ Tandem lift chains; manual lift & travel



MODEL	BRAND	CAPACITY kg	LOAD CENTRE (mm)	MAX FORK HEIGHT (mm)	LOWERED FORK HEIGHT (mm)	OVERALL FORK WIDTH (mm)	FORK WIDTH (mm)	FORK LENGTH (mm)	OVERALL LENGTH (mm)	OVERALL HEIGHT (mm)	OVERALL WIDTH (mm)	GROUND CLEARANCE (mm)	FRONT WHEEL (mm)	REAR WHEEL (mm)	NET WEIGHT (kg)
WRFFS1016	Warrior	1000	500	1600	85	550	160	1150	1660	2100	740	25	ø 74 x 55	ø 180 x 50	172
WRFFS1030	Warrior	1000	500	3000	85	550	160	1150	1668	2060	740	25	ø 74 x 70	ø 180 x 50	310
WRVFS1016	Warrior	1000	500	1600	85	300-800	140	1150	1488	2100	850	20	ø 74 x 55	ø 180 x 50	184
WRVFS1030	Warrior	1000	500	3000	85	300-740	140	1150	1496	2060	800	23	ø 74 x 70	ø 180 x 50	332

WARRIOR Manual Straddle Stacker with Adjustable Forks

Suitable for most pallets

- ▶ Pulling handle
- ▶ Brake
- ▶ Steer wheel foot guards
- ▶ Tandem lift chains
- ▶ Manual lift & travel
- ▶ Adjustable forks



WARRIOR CE

MODEL	BRAND	CAPACITY (kg)	MAX FORK HEIGHT (mm)	LOWERED FORK HEIGHT (mm)	OVERALL FORK WIDTH (mm)	FORK LENGTH (mm)	MIN TURNING RADIUS (mm)	OVERALL LENGTH (mm)	OVERALL WIDTH (mm)	OVERALL HEIGHT (mm)	OUTER DIAMETER FRONT WHEEL (mm)	OUTER DIAMETER REAR WHEEL (mm)	NET WEIGHT (kg)
WRMSS1016	Warrior	1000	1600	75	210-800	1150	1250	1580	1080-1360	2020	80	150	325
WRMSS1025	Warrior	1000	2500	75	210-800	1150	1650	1480	1080-1360	1770	80	150	360
WRMSS1030	Warrior	1000	3000	75	210-800	1150	1650	1480	1080-1360	2020	80	150	385

Semi Electric Stackers

WARRIOR Semi Electric Stacker with Wrapover Forks

- ▶ Heavy Duty 1500W electro-hydraulic power pack
- ▶ Steering / Pulling Handle
- ▶ Brake
- ▶ Steer Wheel Foot Guards
- ▶ Full Guarding
- ▶ Tandem Lift Chains
- ▶ Manual Push / Electric Lift
- ▶ 90° Stacking Aisle (1000mm long x 1200mm wide) 2145mm
- ▶ 12v 150Ah battery
- ▶ Built in Automatic Charger
- ▶ Available with adjustable forks



MODEL	BRAND	CAPACITY kg	LOAD CENTRE (mm)	MAX LIFT HEIGHT (mm)	LOWERED FORK HEIGHT (mm)	OVERALL FORK WIDTH (mm)	FORK LENGTH (mm)	REAR WHEEL SIZE (mm)	FRONT TYRE SIZE (mm)	OVERALL LENGTH (mm)	OVERALL HEIGHT (mm)	EXTENDED MAST HEIGHT (mm)	TURNING RADIUS (mm)	WEIGHT kg
WR1025	Warrior	1000	600	2500	85	570	1100	Ø180 x 50	Ø74 x 70	1720	1830	3070	1400	410
WR1030	Warrior	1000	600	3000	85	570	1100	Ø180 x 50	Ø74 x 70	1720	2080	3570	1400	430
WR1033	Warrior	1000	600	3300	85	570	1100	Ø180 x 50	Ø74 x 70	1720	2230	3870	1400	450

WARRIOR Semi Electric Straddle Stacker with Adjustable Forks

- ▶ Heavy duty 1500W electro-hydraulic power pack
- ▶ Steering/pulling handle; steer wheel foot guards
- ▶ Tandem lift chains
- ▶ Manual push/electric lift
- ▶ 90° stacking aisle (1000mm long x 1200mm wide)
- ▶ 2145mm
- ▶ 12v 150Ah battery & built in automatic charger

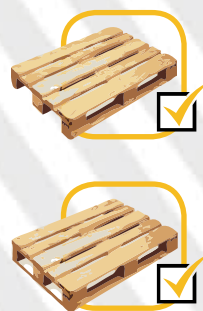

WARRIOR CE

MODEL	BRAND	CAPACITY kg	LOAD CENTRE (mm)	MAX LIFT HEIGHT (mm)	LOWERED FORK HEIGHT (mm)	OVERALL FORK WIDTH (mm)	FORK LENGTH (mm)	REAR WHEEL SIZE (mm)	FRONT TYRE SIZE (mm)	OVERALL LENGTH (mm)	OVERALL WIDTH ADJUSTMENT (mm)	EXTENDED MAST HEIGHT (mm)	LOWERED MAST HEIGHT (mm)	TURNING RADIUS (mm)	WEIGHT kg
WRST1025	Warrior	1000	600	2500	70	200-800	960	Ø180 x 50	Ø80 x 93	1800	1182-1382	3094	1854	1580	690
WRST1030	Warrior	1000	600	3000	70	200-800	960	Ø180 x 50	Ø80 x 93	1800	1182-1382	3594	2104	1580	710

All our products have a full 12 months ON SITE parts & labour warranty

12 MONTHS WARRANTY

Powered Stackers

ECO WARRIOR Mono Self Propelled Stacker

- ▶ Highly specialised drive and hydraulic system
- ▶ Small dimensions for easy movement in confined spaces
- ▶ Excellent driving performance and high reliability
- ▶ Innovative, pressure-sensitive, butterfly accelerator switches
- ▶ Ergonomic all-in-one function handle
- ▶ Pressure sensitive speed control
- ▶ Integrated emergency stop button ensures operator safety
- ▶ On board self-diagnostics
- ▶ Digital display allows easy trouble shooting
- ▶ Battery life indicator
- ▶ Integrated charger unit
- ▶ Safety-first design prevents load falling if oil pipes cut-off
- ▶ Turn circle matches pallet truck
- ▶ Other lift heights available please call...

ES12-12MM/ES12-25MM

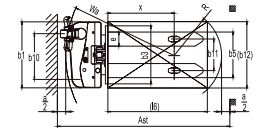
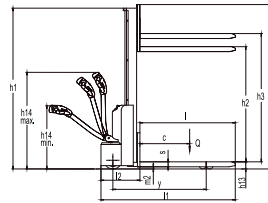

ES12-12ES/ES12-25DM

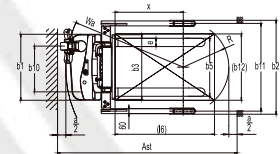
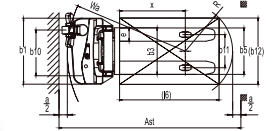
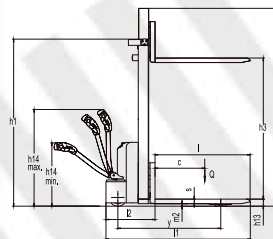

Rated Capacities Graph

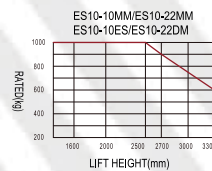

WARRIOR CE

Powered Stackers

The Handling Equipment Shop

The premier name in materials handling...

	MODEL			WRES12-12MM	WRES12-25MM	WRES12-12ES	WRES12-25DM
Distinguishing mark	1.1 Manufacturer			Warrior	Warrior	Warrior	Warrior
	1.2 Model designation			WRES12-12MM	WRES12-25MM	WRES12-12ES	WRES12-25DM
	1.4 Driver unit			Electric	Electric	Electric	Electric
	1.5 Type of operation			Pedestrian	Pedestrian	Pedestrian	Pedestrian
	1.6 Rated capacity	Q	kg	1200	1200	1200	1200
	1.7 Load centre distance	c	mm	600	600	600	600
	1.8 Load distance	x	mm	805	850	795	845
	1.9 Wheelbase	y	mm	1126	1210	1240	1290
	Weight	2.1 Service weight (include battery)		kg	462	543	661
2.2 Axle loading with load, driving side/loading side			kg	741/921	783/960	845/1016	837/1039
2.3 Axle loading without load, driving side/loading side			kg	343/119	420/123	536/125	549/127
Types/Chassis	3.1 Tyre type driving wheels/loading wheels			PU/PU	PU/PU	PU/PU	PU/PU
	3.2 Tyre size, driving wheels (diameter × width)		mm	Ø210 x 70	Ø210 x 70	Ø210 x 70	Ø210 x 70
	3.3 Tyre size, loading wheels (diameter × width)		mm	Ø80 x 60	Ø100 x 50	Ø80 x 60	Ø100 x 50
	3.4 Tyre size, caster wheels (diameter × width)		mm	Ø130 x 55	Ø100 x 50	Ø130 x 55	Ø100 x 50
	3.5 Wheels, number driving/loading (x=drive wheels)		mm	1 x+ 1/4	1 x+ 1/4	1 x+ 1/4	1 x+ 1/4
	3.6 Track width, front, driving side	b ₁₀	mm	533	533	533	533
	3.7 Track width, rear, loading side	b ₁₁	mm	380	1060/1160/1260/1360	400	1060/1160/1260/1360
Dimensions	4.1 Tilt of mast/fork carriage forward/backward	a/β	°	/	/	/	/
	4.2 Height, mast lowered	h ₁	mm	1940	1940	2052	2083
	4.3 Free lift	h ₂	mm	1505	1407	/	/
	4.4 Lift height	h ₃	mm	1520	1520	2930	2930
	4.5 Height, mast extended	h ₄	mm	1955	2053	3487	3895
	4.6 Initial lift	h ₅	mm	/	/	/	/
	4.9 Height drawbar in driving position min./max.	h ₃	mm	860/1200	860/1200	860/1200	860/1200
	4.10 Height of wheel arms	h ₂	mm	/	100	/	/
	4.15 Lowered height	h ₁₃	mm	88	60	88	60
	4.19 Overall length	l ₁	mm	1615	1570	1740	1650
	4.20 Length to face of forks	l ₂	mm	465	500	590	580
	4.21 Overall width	b ₁	mm	800	1135/1235/1335/1435	800	1135/1235/1335/1435
	4.22 Fork dimensions	s/e/l	mm	60/170/1150	35/100/1070	60/170/1150	35/100/1070
	4.24 Fork carriage width	b ₂	mm	680	780	680	800
	4.25 Distance between fork-arms	b ₃	mm	550	200-765	570	200-765
	4.26 Distance between wheel arms	b ₄	mm	/	/	/	/
	4.31 Ground clearance, laden, below mast	m ₂	mm	/	/	/	/
	4.32 Ground clearance, center of wheelbase	m ₂	mm	30	40	30	40
	4.34.1 Aisle width for pallets 1000 × 1200 crossways	Ast	mm	2137	2175	2225	2255
	4.34.2 Aisle width for pallets 800 × 1200 lengthways	Ast	mm	2062	2100	2150	2180
	4.35 Turning radius	Wa	mm	1295	1329	1408	1404
Performance	5.1 Travel speed, laden/ unladen		km/h	3.5/4	3.5/4	3.5/4	3.5/4
	5.2 Lifting speed, laden/ unladen		m/s	0.12/0.22	0.12/0.22	0.12/0.22	0.12/0.22
	5.3 Lowering speed, laden/ unladen		m/s	0.12/0.11	0.12/0.11	0.12/0.11	0.12/0.11
	5.8 Max. gradeability, laden/unladen		%	3/10	3/10	3/10	3/10
	5.10 Service brake type			Electromagnetic	Electromagnetic	Electromagnetic	Electromagnetic
Electric/engine	6.1 Drive motor rating S2 60 min		kW	0.65	0.65	0.65	0.65
	6.2 Lift motor rating at S3 15%		kW	2.2	2.2	2.2	2.2
	6.3 The maximum allowed size battery		mm	270 x 180 x 230	270 x 180 x 230	325 x 180 x 230	325 x 180 x 230
	6.4 Battery voltage/nominal capacity K20		V/Ah	2 x 12/85	2 x 12/85	2 x 12/105	2 x 12/105
	6.5 Battery weight		kg	2 x 25	2 x 25	2 x 30	2 x 30
Others	8.1 Type of drive unit			DC	DC	DC	DC
	10.5 Steering type			Mechanical	Mechanical	Mechanical	Mechanical
	10.7 Sound pressure level at the driver's ear			74	74	74	74

1. The parameters in the table are of the standard model. For more information please contact us.
2. The parameters are subject to change without notice.

All our products have a full 12 months ON SITE parts & labour warranty

12 MONTHS WARRANTY

Powered Stackers

WARRIOR Mini Counterbalanced Stacker

Many applications don't warrant a full tonne capacity, so the **WARRIOR** Mini Counterbalanced Stacker fits this category perfectly

- ▶ Robust
- ▶ Ergonomic
- ▶ Efficient
- ▶ Reliable
- ▶ Compact
- ▶ Manoeuvrable

Additional Features

- ▶ Various lift heights available
- ▶ Adjustable forks
- ▶ Tilting carriage available
- ▶ Anti roll back control
- ▶ E stop
- ▶ Overload protection
- ▶ Lift lockout below 20% power
- ▶ Ease of access for repairs and maintenance
- ▶ Fully programmable parameters
- ▶ Side access battery compartment
- ▶ Fully automatic battery charger



WARRIOR

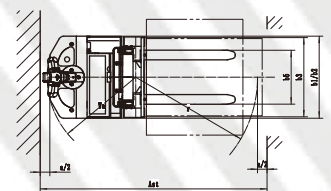
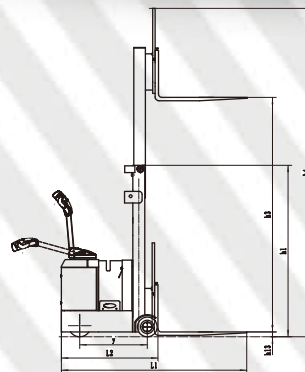

Powered Stackers

The Handling Equipment Shop

The premier name in materials handling...

	MODEL			WRES06-CA
Distinguishing mark	1.1 Manufacturer			Warrior
	1.2 Model designation			ES06-CA
	1.4 Driver unit			Electric
	1.5 Type of operation			Pedestrian
	1.6 Rated capacity	Q	kg	600
	1.7 Load centre distance	c	mm	500
	1.8 Load distance	x	mm	109
	1.9 Wheelbase	y	mm	700
	Weight	2.1 Service weight (include battery)		kg
2.2 Axle loading with load, driving side/loading side			kg	300/1900
2.3 Axle loading without load, driving side/loading side			kg	860/440
Types/Chassis	3.1 Tyre type driving wheels/loading wheels			PU/PU
	3.2 Tyre size, driving wheels (diameter × width)		mm	Ø230 x 75
	3.3 Tyre size, loading wheels (diameter × width)		mm	Ø204 x 76
	3.4 Tyre size, caster wheels (diameter × width)		mm	/
	3.5 Wheels, number driving/loading (x=drive wheels)		mm	1 x 0/2
	3.6 Track width, front, driving side	b ₁₀	mm	722
	3.7 Track width, rear, loading side	b ₁₁	mm	/
Dimensions	4.1 Tilt of mast/fork carriage forward/backward	a/β	°	/
	4.2 Height, mast lowered	h ₁	mm	2035
	4.3 Free lift	h ₂	mm	/
	4.4 Lift height	h ₃	mm	2920
	4.5 Height, mast extended	h ₄	mm	3896
	4.9 Height drawbar in driving position min./max.	h ₃	mm	990/1500
	4.10 Height of wheel arms	h ₃	mm	230
	4.15 Lowered height	h ₁₃	mm	50
	4.19 Overall length	l ₁	mm	1920
	4.20 Length to face of forks	l ₂	mm	1000
	4.21 Overall width	b ₁	mm	850/798
	4.22 Fork dimensions	s/e/l	mm	35/100/920
	4.24 Fork carriage width	b ₃	mm	820
	4.25 Distance between fork-arms	b ₅	mm	200-560
	4.31 Ground clearance, laden, below mast	m ₂	mm	50
	4.32 Ground clearance, center of wheelbase	m ₂	mm	50
	4.34.1 Aisle width for pallets 1000 × 1200 crossways	Ast	mm	2380
4.34.2 Aisle width for pallets 800 × 1200 lengthways	Ast	mm	2490	
4.35 Turning radius	Wa	mm	1060	
Performance	5.1 Travel speed, laden/ unladen		km/h	4.5
	5.2 Lifting speed, laden/ unladen		m/s	0.12/0.22
	5.3 Lowering speed, laden/ unladen		m/s	0.12/0.11
	5.8 Max. gradeability, laden/unladen		%	5.0/8.0
	5.10 Service brake type			Electromagnetic
Electric/engine	6.1 Drive motor rating S2 60 min		kW	1.5
	6.2 Lift motor rating at S3 15%		kW	2.2
	6.3 The maximum allowed size battery		mm	660/230/open
	6.4 Battery voltage/nominal capacity K20		V/Ah	24/165
	6.5 Battery weight		kg	160
Others	8.1 Type of drive unit			AC
	10.5 Steering type			Mechanical
	10.7 Sound pressure level at the driver's ear			74

1. The parameters in the table are of the standard model. For more information please contact us.
2. The parameters are subject to change without notice.

All our products have a full 12 months ON SITE parts & labour warranty

12 MONTHS WARRANTY

Powered Stackers

WARRIOR Electric Stacker 1200kg

Medium duty pedestrian controlled power stacker.

- ▶ Robust
- ▶ Ergonomic
- ▶ Efficient
- ▶ Reliable
- ▶ Compact
- ▶ Manoeuvrable

Additional Features

- ▶ Electronic power steering
- ▶ Various lift heights available
- ▶ Fixed forks
- ▶ Anti roll back control
- ▶ E stop
- ▶ Overload protection
- ▶ Lift lockout below 20% power
- ▶ Ease of access for repairs and maintenance
- ▶ Fully programmable parameters
- ▶ Fully automatic battery charger



WARRIOR CE

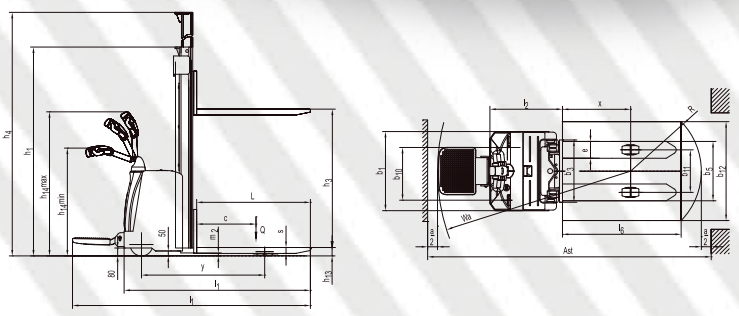

Powered Stackers

The Handling Equipment Shop

The premier name in materials handling...

	MODEL			WRES12-RS
Distinguishing mark	1.1 Manufacturer			Warrior
	1.2 Model designation			ES12-RS
	1.3 Driver unit			Electric
	1.4 Type of operation			Standing
	1.5 Rated capacity	Q	kg	1200
	1.6 Load centre distance	c	mm	600
	1.8 Load distance, centre of drive axle to fork	x	mm	690
	1.9 Wheelbase	y	mm	1245
	Weight	2.1 Service weight (include battery)		kg
2.2 Axle loading, laden driving side/loading side			kg	795/1365
2.3 Axle loading, unladen driving side/loading side			kg	660/300
Types/Chassis	3.1 Tyre type driving wheels/loading wheels			PU/PU
	3.2 Tyre size, driving wheels (diameter × width)		mm	Ø230 x 75
	3.3 Tyre size, loading wheels (diameter × width)		mm	Ø85 x 70
	3.4 Tyre size, caster wheels (diameter × width)		mm	Ø130 x 55
	3.5 Wheels, number driving/loading (x=drive wheels)		mm	1x+ 1/4
	3.6 Track width, front, driving side	b ₁₀	mm	533
	3.7 Track width, rear, loading side	b ₁₁	mm	380/430/515
Dimensions	4.1 Tilt of mast/fork carriage forward/backward	a/β	°	/
	4.2 Height, mast lowered	h ₁	mm	1962
	4.3 Free lift	h ₂	mm	100
	4.4 Lift height	h ₃	mm	2930
	4.5 Height, mast extended	h ₄	mm	3400
	4.9 Height drawbar in driving position min./max.	h ₃	mm	1150/1480
	4.10 Height of wheel arms	h ₃	mm	/
	4.15 Lowered height	h ₁₃	mm	88
	4.19 Overall length	l ₁	mm	1975/2405
	4.20 Length to face of forks	l ₂	mm	560
	4.21 Overall width	b ₁	mm	800
	4.22 Fork dimensions	s/e/l	mm	60/170/1150
	4.24 Fork carriage width	b ₃	mm	630
	4.25 Distance overall forks	b ₅	mm	550
	4.32 Ground clearance, center of wheelbase	m ₂	mm	28
	Performance	4.34.1 Aisle width for pallets 1000 × 1200 crossways	Ast	mm
4.34.2 Aisle width for pallets 800 × 1200 lengthways		Ast	mm	2420/2803
4.35 Turning radius		Wa	mm	1571/1954
5.1 Travel speed, laden/ unladen			km/h	5.0/5.5
5.2 Lifting speed, laden/ unladen			m/s	0.14/0.22
Electric/engine	5.3 Lowering speed, laden/ unladen		m/s	0.18/0.2
	5.8 Max. gradeability, laden/unladen		%	8/16
	5.10 Service brake type			Electromagnetic
	6.1 Drive motor rating S2 60 min		kW	1.6
	6.2 Lift motor rating at S3 15%		kW	2.2
Others	6.3 The maximum allowed size battery		mm	750 x 525 x 175
	6.4 Battery voltage/nominal capacity K5		V/Ah	24/165
	6.5 Battery weight		kg	165
	8.1 Type of drive unit			AC ZAPI
	10.5 Steering type			Electronic
	10.7 Sound pressure level at the driver's ear			74

1. The parameters in the table are of the standard model. For more information please contact us.
2. The parameters are subject to change without notice.

All our products have a full 12 months ON SITE parts & labour warranty

12 MONTHS WARRANTY

Powered Stackers

WARRIOR Full Electric Heavy Duty Stacker

Heavy duty pedestrian controlled power stacker.

- ▶ Robust
- ▶ Ergonomic
- ▶ Efficient
- ▶ Reliable
- ▶ Compact
- ▶ Manoeuvrable

Additional Features

- ▶ Electronic power steering
- ▶ Various lift heights available
- ▶ Fixed forks
- ▶ Anti roll back control
- ▶ E stop
- ▶ Overload protection
- ▶ Lift lockout below 20% power
- ▶ Ease of access for repairs and maintenance
- ▶ Fully programmable parameters
- ▶ Fully automatic battery charger



WARRIOR CE

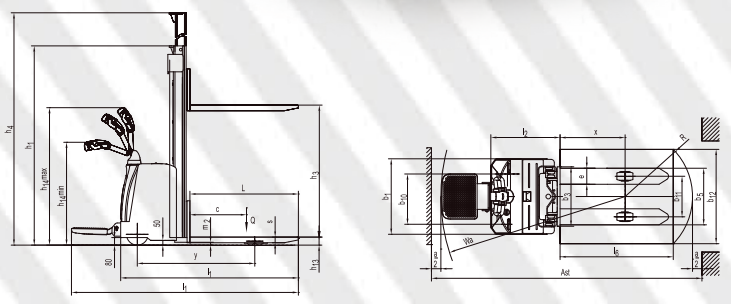

Powered Stackers

The Handling Equipment Shop

The premier name in materials handling...

	MODEL			WRES16-RS
Distinguishing mark	1.1 Manufacturer			Warrior
	1.2 Model designation			ES16-RS
	1.3 Driver unit			Electric
	1.4 Type of operation			Standing
	1.5 Rated capacity	Q	kg	1600
	1.6 Load centre distance	c	mm	600
	1.8 Load distance, centre of drive axle to fork	x	mm	693
	1.9 Wheelbase	y	mm	1375
	Weight	2.1 Service weight (include battery)		kg
2.2 Axle loading, laden driving side/loading side			kg	960/1880
2.3 Axle loading, unladen driving side/loading side			kg	860/380
Types/Chassis	3.1 Tyre type driving wheels/loading wheels			PU/PU
	3.2 Tyre size, driving wheels (diameter × width)		mm	Ø230 x 75
	3.3 Tyre size, loading wheels (diameter × width)		mm	Ø85 x 70
	3.4 Tyre size, caster wheels (diameter × width)		mm	Ø130 x 55
	3.5 Wheels, number driving/loading (x=drive wheels)		mm	1x+ 1/4
	3.6 Track width, front, driving side	b ₁₀	mm	574
3.7 Track width, rear, loading side	b ₁₁	mm	380/410/495	
Dimensions	4.1 Height, mast lowered	h ₁	mm	2020
	4.2 Free lift	h ₂	mm	100
	4.4 Lift height	h ₃	mm	2950
	4.5 Height, mast extended	h ₄	mm	3465
	4.9 Height drawbar in driving position min./max.	h ₁₄	mm	1150/1480
	4.15 Lowered height	h ₁₃	mm	88
	4.19 Overall length	l ₁	mm	2495
	4.20 Length to face of forks	l ₂	mm	879
	4.21 Overall width	b ₁	mm	850
	4.22 Fork dimensions	s/e/l	mm	60 x 190 x 1150
	4.24 Fork carriage width	b ₃	mm	800
	4.25 Distance overall forks	b ₅	mm	570
	4.32 Ground clearance, center of wheelbase	m ₂	mm	28
	4.34.1 Aisle width for pallets 1000 × 1200 crossways	Ast	mm	2605/2965
	4.34.2 Aisle width for pallets 800 × 1200 lengthways	Ast	mm	2575/2935
4.35 Turning radius	Wa	mm	1730/2090	
Performance	5.1 Travel speed, laden/unladen		km/h	5.5/6.0
	5.2 Lifting speed, laden/unladen		m/s	0.13/0.16
	5.3 Lowering speed, laden/unladen		m/s	0.32/0.23
	5.8 Max. gradeability, laden/unladen		%	8/16
	5.10 Service brake type			Electromagnetic
Electric/engine	6.1 Drive motor rating S2 60 min		kW	1.6
	6.2 Lift motor rating at S3 15%		kW	3.0
	6.3 The maximum allowed size battery		mm	834 x 216 x 630
	6.4 Battery voltage/nominal capacity K5		V/Ah	24/210
	6.5 Battery weight		kg	200
Others	8.1 Type of drive unit			AC
	10.5 Steering type			Electronic
	10.7 Sound pressure level at the driver's ear			74

1. The parameters in the table are of the standard model. For more information please contact us.
2. The parameters are subject to change without notice.

All our products have a full 12 months ON SITE parts & labour warranty

12 MONTHS WARRANTY

Powered Stackers

WARRIOR ACS Compact Powered Counterbalanced Stacker

MODEL	WRACS
Brand	Warrior
Capacity	800kg-1500kg @ 500mm Load Centre
Standard Lift Height	2500mm
Chassis Length	1495mm-1945mm
Fork Length	1070mm
Fork Adjustment	200/770mm
Overall Width	990mm
Turning Radius	1180mm-1630mm
Drive Motor	1.6Kw
Battery	240Ah/5 Hr

**DEMO
MODEL
AVAILABLE**

- ▶ Powered Steering (less than 1kg of effort required)
- ▶ Zapi AC Power Controller
- ▶ Load Backrest; Electro Magnetic Brakes
- ▶ Reversing Alarm; Anti Pinning Button
- ▶ Horn; Battery State Meter



WARRIOR CE

Powered Stackers

The Handling Equipment Shop

The premier name in materials handling...

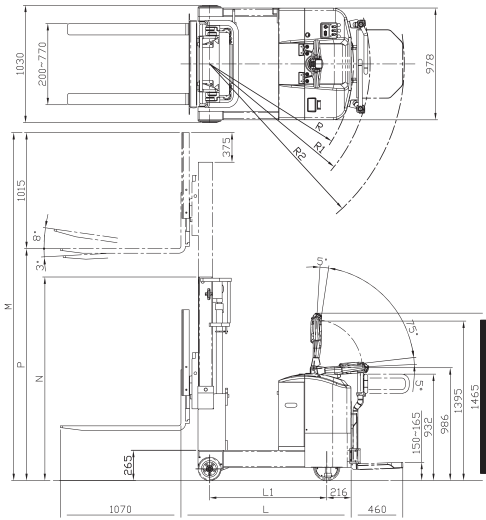

WARRIOR MODEL	WRACS-08	WRACS-10	WRACS-12	WRACS-15
Rated capacity	800kg	1000kg	1200kg	1500kg
Load centre	500mm	500mm	500mm	500mm
Lift Height (std)	2500mm	2500mm	2500mm	2500mm
Chassis Length (L)	1495mm	1595mm	1715mm	1945mm
Fork Length	1070mm	1070mm	1070mm	1070mm
Chassis Width	978mm	978mm	978mm	978mm
Overall Width	990mm	990mm	990mm	990mm
Turning Radius	1180mm	1280mm	1280mm	1630mm
Fork Adjustment	200/770mm	200/770mm	200/770mm	200/770mm
Fork Tilt (fwd/bwd)	2/8°	2/8°	2/8°	2/8°
Travel speed Loaded	5.5km/h	5.5km/h	5.5km/h	5.5km/h
Travel speed Empty	6km/h	6km/h	6km/h	6km/h
Lift speed Loaded	90mm/s	90mm/s	90mm/s	100mm/s
Lift speed Empty	200mm/s	200mm/s	200mm/s	200mm/s
Drive Motor	1.6Kw	1.6Kw	1.6Kw	1.6Kw
Steering Motor	0.4Kw	0.4Kw	0.4Kw	0.4Kw
Lift Motor	3.5Kw	3.5Kw	3.5Kw	3.5Kw
Max Gradient Loaded	6°	6°	6°	6°
Max Gradient Empty	8°	8°	8°	8°
Drive Controller	AC	AC	AC	AC
Lift Controller	DC	DC	DC	DC
Traction Battery (24V)	240 Ah/5Hr	240 Ah/5Hr	240 Ah/5Hr	240 Ah/5Hr
Wheels	PU	PU	PU	PU

MAST TYPES	MAX. LIFT HEIGHT (P) (mm)								
	2000	2500	3000	3500	4000	4500	5000	5500	6000
DUPLIX MAST TELESCOPIC									
MIN MAST HEIGHT (N)	1610	1860	2110	2360	2610	-	-	-	-
MAX MAST HEIGHT (M)	3065	3565	4065	4565	5065	-	-	-	-
DUPLIX MAST HI-LO FULL FREE LIFT									
MIN MAST HEIGHT (N)	1610	1860	2110	2360	2610	-	-	-	-
MAX MAST HEIGHT (M)	3065	3565	4065	4565	5065	-	-	-	-
MAX FREE LIFT	950	1224	1490	1740	1998	-	-	-	-
TRIPLE STAGE MAST H-LO FULL FREE LIFT									
MIN MAST HEIGHT (N)	-	-	1610	1860	1960	2110	2260	2460	2610
MAX MAST HEIGHT (M)	-	-	4065	4565	5065	5565	6065	6565	7065
MAX FREE LIFT	-	-	830	1000	1324	1400	1650	1820	2000

All our products have a full 12 months ON SITE parts & labour warranty



Powered Stackers

WARRIOR ART Compact Powered Reach Stacker

MODEL		WRART10	WRART15	WRART20
Brand		Warrior	Warrior	Warrior
Capacity		1000kg	1500kg	2000kg
Truck Length	L	1790mm	1790mm	1990mm
Truck Width		978mm	978mm	978mm
Wheel Base	L1	1380mm	1380mm	1580mm
Total Length with Draw		2210mm	2210mm	2410mm
Overall Length Extended		2860mm	2860mm	3160mm
Fork Length		1070mm	1070mm	1070mm
Turning Radius	R	1618mm	1618mm	1818mm
Turning Radius	R1	1766mm	1766mm	1966mm
Turning Radius	R2	2070mm	2070mm	2270mm
Mast Reach Length	V	650mm	650mm	750mm
Fork Wheel Width		103mm	103mm	103mm
Fork Adjustable Width		200-710mm	200-710mm	200-710mm
Height of Straddle		265mm	265mm	265mm



- ▶ Powered Steering (less than 1kg of effort required)
- ▶ Zapi AC Power Controller
- ▶ Load Backrest; Electro Magnetic Brakes
- ▶ Reversing Alarm; Anti Pinning Button
- ▶ Horn; Battery State Meter



WARRIOR CE

Powered Stackers

The Handling Equipment Shop

The premier name in materials handling...

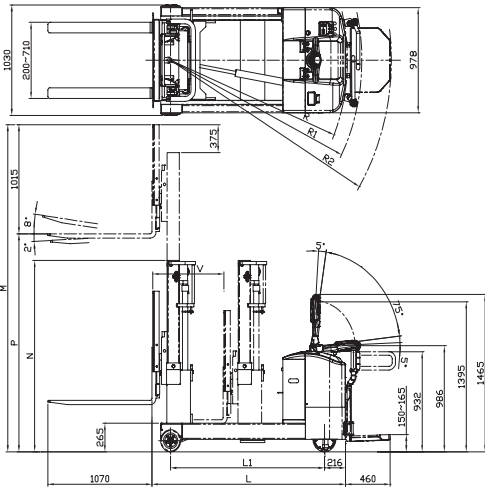

NEW MODEL

	WARRIOR MODEL	WRART-10	WRART-15	WRART-20	
Lifting	Rated capacity	1000kg	1500kg	2000kg	
	Load centre	500 mm			
	Forks (T x W x L)	40x100x1070mm	40x100x1070mm	45x100x1070mm	
	Lifting speed	loaded	125 mm/s	125 mm/s	90mm/s
		empty	190 mm/s		
	Lowering speed	loaded	180 mm/s	180 mm/s	180 mm/s
		empty	208 mm/s		
	Travel speed	loaded	5.5 km/h	4.5 km/h	4.5 km/h
		empty	6 km/h		
	Gradeability	loaded	8%		
empty		24%			
Fork lifting angle (F/R)	2° / 8°				
Weight of truck	with Battery	1850 kg	1865 kg	1945 kg	
	without Battery	1635 kg	1650 kg	1730 kg	
Wheels	Fork Wheels	dimension Ø 205 x 70mm			
		quantity (R/L)			
		material			
	Drive wheel	dimension Ø235 x 120mm			
	material				
Battery & Motors	Battery capacity at 5 hours charge (24V)	240AH			
	Max. charging current (24V)	40A			
	Drive motor power (24V)	1.6 kw			
	Steering motor power (24V)	0.4 kw			
	Lifting motor power (24V)	3.5 kw			
Steering & Brake	Inverter	AC Stepless			
	Steering System	Steering Arm			
	Steering arc.total	185 degree			
	Travelling	Type	Electromagnetic spring pressure		
		Actuated	Drive wheel		
	Parking brake	Type	Electromagnetic spring pressure		
		Actuated	Drive wheel		
Reverse Alarm Device	Standard	Beeper			

MAST TYPES	MAX. FORK HEIGHT (P) (mm)									
	2000	2500	3000	3500	4000	4500	5000	5500	6000	6350
DUPLIX MAST TELESCOPIC										
MIN MAST HEIGHT (N)	1610	1860	2110	2360	2610	-	-	-	-	-
MAX MAST HEIGHT (M)	3065	3565	4065	4565	5065	-	-	-	-	-
DUPLIX MAST HI-LO FULL FREE LIFT										
MIN MAST HEIGHT (N)	1610	1860	2110	2360	2610	-	-	-	-	-
MAX MAST HEIGHT (M)	3065	3565	4065	4565	5065	-	-	-	-	-
MAX FREE LIFT	990	1190	1440	1780	2040	-	-	-	-	-
TRIPLE STAGE MAST H-LO FULL FREE LIFT										
MIN MAST HEIGHT (N)	-	-	1610	1860	1960	2110	2260	2460	2610	2730
MAX MAST HEIGHT (M)	-	-	4065	4565	5065	5565	6065	6565	7065	7415
MAX FREE LIFT	-	-	830	1000	1324	1400	1650	1820	2000	2116

All our products have a full 12 months ON SITE parts & labour warranty

12 MONTHS WARRANTY

Micro Forklifts

Mariotti Micro Forklifts

MODEL	WRAC (Mycros)
Brand	Mariotti
Capacity	400kg-1300kg
Maximum Lift Height	5700mm
Closed Height (minimum)	1950mm
Chassis Length (from)	1095mm Plus
Chassis Width (from)	830mm Plus
Battery	24V and 36V

- ▶ AC Drive & Lift
- ▶ Powered Steering; Cushion Tyres
- ▶ Suspension Seat with Sidearm
- ▶ Integrated Sideshift
- ▶ Rear RED Lights; Digital LCD Dash Display
- ▶ Integral Sideshift; Safe Cornering Control
- ▶ "Regen" Braking, Flashing Beacon & Low Mounted Flashing Beacon



MODEL	WRMEAC
Brand	Mariotti
Capacity	600kg-1200kg
Maximum Lift Height	5700mm
Closed Height (minimum)	1915mm
Chassis Length (from)	1420mm
Chassis Width (from)	800mm
Battery	24V and 36V



- ▶ AC Drive & DC Lift
- ▶ Powered Steering & Cushion Tyres
- ▶ Integrated Sideshift
- ▶ Suspension Seat with Sidearm
- ▶ "Regen" Braking
- ▶ Rear Drive
- ▶ Flashing Beacon

Tow Tractors

WARRIOR QDD60 Seated Electric Tow Tractor

- ▶ CE marked
- ▶ Zapi programmable controller
- ▶ Powered steering
- ▶ Operator comfort pad
- ▶ Hour meter, beacon
- ▶ Battery meter & Pin type towing truck

WARRIOR CE

Professional Heavy Duty Tug Trucks

NEW



MODEL		QDD60	QDD60TS-C
Brand		Warrior	Warrior
Rated Capacity	kg	6000	6000
Rated Drawbar Pull	N	600	1200
Service Weight	kg	1150	1150
Overall Length	mm	1966	1966
Overall Width	mm	990/1010	990/1010
Loading Platform, Width	mm	700	700
Turning Radius	WA	1850	1800
Travel Speed, Laden/ Unladen	km/h	9.5/10.5	7-17
Max. Drawbar Pull, Laden/Unladen S2 5 min	N	6500	4500
Gradeability, Laden/Unladen S2 30 min	%	5-10	
Battery Voltage/Nominal Capacity 5h	V/Ah	48/275	48/275

WARRIOR ATT50 Pedestrian Controlled Tow Tractor

MODEL	WRATT50
Brand	Warrior
Capacity	5000kg (level ground) 3000kg (with 10% gradeability)
Minimum Speed (Laden)	4.5km/h
Minimum Speed (Empty)	7.1km/h
Overall Length	1406mm
Overall Width	938mm
Truck Weight (with battery)	688kg
Battery	240Ah
Charger	40A / 12 Hr
Tyres	Polyurethane
Load Wheel	205 x 70mm
Drive Wheel	212 x 70mm(solid tyre)

- ▶ CE marked
- ▶ Zapi AP System
- ▶ Zapi powered steering
- ▶ Optional seat
- ▶ Lead free PU



Heavy duty, robust and simple to use

WARRIOR CE

All our products have a full 12 months ON SITE parts & labour warranty

12 MONTHS WARRANTY

Specials

WARRIOR Specials

SPECIALS!

Get **BESPOKE**
Handling Equipment
MADE TO MEASURE



Lift Tables

ECO WARRIOR Manual Operated Mobile Lift Tables

Our comprehensive range of mobile lift tables are manufactured to withstand the most arduous working environments normally associated with industrial applications

- ▶ Robust & reliable
- ▶ High quality hydraulics with a positive feel
- ▶ Foot operated lift
- ▶ Infinitely controlled lower
- ▶ High pushing handle
- ▶ Foot brakes fitted to swivel castors



WARRIOR CE

Double Scissor



Single Scissor



MODEL	BRAND	CAPACITY	LOWERED TABLE HEIGHT	RAISED TABLE HEIGHT	TABLE SIZE W x L (mm)	HANDLE HEIGHT	WHEEL DIAMETER	NUMBER OF STROKES TO FULL LIFT HEIGHT	SCISSOR TYPE	NET WEIGHT
WR15	Warrior	150kg	220mm	720mm	450 x 700mm	950mm	100mm	28	Single	46kg
WR30	Warrior	300kg	285mm	880mm	500 x 850mm	990mm	125mm	27	Single	74kg
WR50	Warrior	500kg	285mm	880mm	500 x 850mm	990mm	125mm	27	Single	81kg
WR50L	Warrior	500kg	290mm	915mm	810 x 1600mm	975mm	125mm	55	Single	154kg
WR75	Warrior	750kg	420mm	990mm	510 x 1000mm	990mm	147mm	45	Single	125kg
WR100	Warrior	1000kg	380mm	990mm	510 x 1016mm	990mm	147mm	82	Single	140kg
WR100L	Warrior	1000kg	360mm	1360mm	750 x 2035mm	1000mm	180mm/80mm	200	Single	198kg
WR350	Warrior	350kg	335mm	1300mm	500 x 910mm	975mm	125mm	53	Double	105kg
WR800	Warrior	700kg	445mm	1500mm	610 x 1220mm	1015mm	125mm	97	Double	195kg

All our products have a full 12 months ON SITE parts & labour warranty

12 MONTHS WARRANTY

Lift Tables

WARRIOR Premium Manual Operated Mobile Lift Tables

- ▶ Robust & reliable
- ▶ High quality hydraulics with a positive feel
- ▶ Foot operated pump
- ▶ Hand operated infinitely controllable lowering
- ▶ High pushing handle
- ▶ Foot braking and guarding to castors
- ▶ Fully mobile on 2 swivel and 2 fixed castors
- ▶ Fitted with 2 maintenance stops & overload valve



WARRIOR CE



MODEL	BRAND	CAPACITY kg	TABLE HEIGHT Lowered / Raised	TABLE SIZE L x W (mm)	HANDLE HEIGHT	WHEEL DIAMETER	LIFT STROKES TO MAX HEIGHT	SCISSOR TYPE	WEIGHT kg
WRBS15	Warrior	150	265 / 755	700 x 450	1000mm	100mm	16	Single	41
WRBS25	Warrior	250	330 / 910	830 x 500	1100mm	125mm	25	Single	78
WRBS50	Warrior	500	435 / 1000	1010 x 520	1130mm	150mm	44	Single	118
WRBS50L	Warrior	500	400 / 1100	1525 x 620	1130mm	150mm	70	Single	175
WRBS50LB	Warrior	500	370 / 1190	1200 x 800	1030mm	160mm	80	Single	160
WRBS75	Warrior	750	442 / 1000	1010 x 520	1130mm	150mm	55	Single	120
WRBS100	Warrior	1000	445 / 950	1010 x 520	1130mm	150mm	75	Single	137
WRBS100L	Warrior	1000	425 / 1225	1200 x 800	1130mm	150mm	85	Single	163
WRBS300	Warrior	300	435 / 1585	1010 x 520	1130mm	150mm	75	Double	150
WRBS500	Warrior	500	440 / 1575	1010 x 520	1130mm	150mm	75	Double	168
WRBS800	Warrior	800	470 / 1410	1010 x 520	1130mm	150mm	80	Double	165

Lift Tables

ECO WARRIOR Semi electric Mobile lift tables

- ▶ The **WARRIOR** semi electric lift table are recommended for repetitive applications
- ▶ 4 models available
- ▶ Robust design
- ▶ Battery and charger out side main chassis giving lower closed height
- ▶ Fully sealed maintenance free battery
- ▶ Reliable brakes ensures safety and stability
- ▶ Lightweight yet robustly constructed

WARRIOR CE



MODEL	CAPACITY	MAX TABLE HEIGHT	MIN TABLE HEIGHT	TABLE TOP SIZE	CASTER WHEEL DIMENSIONS	HANDLE HEIGHT	OVERALL LENGTH	BATTERY SPEC	LIFTING MOTOR (DC 24V)	BUILT IN CHARGER	NET WEIGHT
WRETF30	300kg	880mm	290mm	850x500x50mm	125 x 40mm	920mm	920mm	24V / 30Ah	0.8kw	8.5Hr	115kg
WRETF50	500kg	1025mm	440mm	1010x520x50mm	150 x 48mm	970mm	1025mm	24V / 24Ah	0.8kw	8.5Hr	157kg
WRETF35	350kg	1300mm	370mm	910x500x53mm	125 x 40mm	935mm	1300mm	24V / 30Ah	0.8kw	8.5Hr	142kg
WRETF75	750kg	970mm	420mm	1000x510x55mm	147 x 50mm	920mm	970mm	24V / 30Ah	0.8kw	8.5Hr	160kg

All our products have a full 12 months ON SITE parts & labour warranty

12 MONTHS WARRANTY

Lift Tables

WARRIOR Auto Pallet Leveller WRSP360-2000

The **WARRIOR** Pallet Leveller is an ingenious self levelling lift table / work positioner which is now an alternative to the only power free automatic pallet leveller on the market. Reduce your risk of a manual handling injury by using the **WARRIOR** Pallet Leveller which automatically positions the load to minimise musculoskeletal strains.



Scan for Video

- ▶ Load range 200-2000 kg capacity (3 springs/4 combinations)
- ▶ Max load dims 1422mm x 1270mm x 1829mm high
- ▶ Max raised height 705mm
- ▶ Min closed height 241mm
- ▶ Rotating Turntable to reduce stretching - Ø 1107mm
- ▶ Solid design
- ▶ Easily change spring combo for different load profile
- ▶ Fork pockets
- ▶ Net weight 173Kg- Levelling feet optional
- ▶ No power source required
- ▶ Creates ideal working height, eliminating bending
- ▶ When placing order, we require load parameters
- ▶ Optional - safety skirt



Reduce your risk of a manual handling injury by using the **WARRIOR pallet leveller** which automatically positions the load to minimise musculoskeletal strains.



Stabilising feet shown are optional extras

WARRIOR CE

Lift Tables

WARRIOR Static Lift Tables (Mains Operated)

- ▶ Remote power system, easy for controlling, convenient for maintenance
- ▶ Electronic control box with up, down, & emergency buttons
- ▶ Specially designed in "U" shape for handling pallets and boxes

WRSLPU10



MODEL	WRSLPU10
Brand	Warrior
Capacity	1000kg
Lowered Height	80mm
Raised Height	760mm
Platform Size	1450mm x 1140mm
Platform Cut Out	1050mm x 585mm
Lifting Time	18 seconds
Lifting Speed with Load	42mm/sec
Lowering Speed with Load	48mm/sec
Motor	0.75kw
Net Weight	235kg

MODEL	WRSLPFT10
Brand	Warrior
Capacity	1000kg
Lowered Height	82mm
Raised Height	760mm
Platform Size	1450mm x 1140mm
Ramp Size	1140mm x 890mm
Lifting Time	18 seconds
Lifting Speed with Load	42mm/sec
Lowering Speed with Load	48mm/sec
Motor	0.75kw
Net Weight	250kg



WRSLPFT10

WARRIOR CE

All our products have a full 12 months ON SITE parts & labour warranty

12 MONTHS WARRANTY

Lift Tables

WARRIOR Static Lift Tables (Mains Operated)

- ▶ **WARRIOR** static mains operated lift tables can either be floor or pit mounted
- ▶ Lift heights up to 1780mm helping to alleviate musculoskeletal injuries
- ▶ Robustly constructed for arduous applications
- ▶ Emergency check valve for controlled decent in a system failure
- ▶ Fully interlocked arrestors

WRHD2000



WARRIOR CE



**Double
Scissor
Table**

MODEL	WRSLT10	WRSLT20	WRSLT30	WRHD2000
Brand	Warrior	Warrior	Warrior	Warrior
Capacity	1000kg	2000kg	3000kg	2000kg
Max. Height	1010mm	1010mm	1020mm	1780mm
Min. Height	190mm	190mm	220mm	360mm
Platform Size	1300 x 800mm	1300 x 800mm	1300 x 800mm	1300 x 850mm
Lifting Time	25 seconds	40 seconds	26 seconds	40 seconds
Lowering Time	20 seconds	30 seconds	22 seconds	35 seconds
Motor	0.75 kw	0.75 kw	1.50 kw	2.2 kw
Weight	220 kg	280 kg	320 kg	295 kg

WARRIOR CE

Lift Tables

The Handling Equipment Shop

The premier name in materials handling...

MODEL	CAPACITY	LOWERED HEIGHT (mm)	RAISED HEIGHT (mm)	PLATFORM SIZE (mm)	BASE FRAME SIZE (mm)	LIFT TIME (secs)	POWER PACK	NET WEIGHT (kg)
WRHW1001	1000	205	1000	820 x 1300	640 x 1240	20-25	380v/50HZ, AC1.1kw	160
WRHW1002	1000	205	1000	1000 x 1600	640 x 1240	20-25	380v/50HZ, AC1.1kw	186
WRHW1003	1000	240	1300	850 x 1700	640 x 1580	30-35	380v/50HZ, AC1.1kw	200
WRHW1004	1000	240	1300	1000 x 1700	640 x 1580	30-35	380v/50HZ, AC1.1kw	210
WRHW1005	1000	240	1300	850 x 2000	640 x 1580	30-35	380v/50HZ, AC1.1kw	212
WRHW1006	1000	240	1300	1000 x 2000	640 x 1580	30-35	380v/50HZ, AC1.1kw	223
WRHW2001	2000	230	1050	850 x 1300	785 x 1220	20-25	380v/50HZ, AC1.5kw	235
WRHW2002	2000	230	1050	1000 x 1600	785 x 1220	20-25	380v/50HZ, AC1.5kw	268
WRHW2003	2000	250	1300	850 x 1700	785 x 1600	25-35	380v/50HZ, AC1.5kw	289
WRHW2004	2000	250	1300	1000 x 1700	785 x 1600	25-35	380v/50HZ, AC1.5kw	300
WRHW2005	2000	250	1300	850 x 2000	785 x 1600	25-35	380v/50HZ, AC1.5kw	300
WRHW2006	2000	250	1300	1000 x 2000	785 x 1600	25-35	380v/50HZ, AC1.5kw	315
WRHW4001	4000	240	1100	1200 x 1700	900 x 1600	30-40	380v/50HZ, AC2.2kw	375
WRHW4002	4000	240	1100	1200 x 2000	900 x 1600	30-40	380v/50HZ, AC2.2kw	405
WRHW4003	4000	300	1400	1000 x 2000	900 x 2000	45-50	380v/50HZ, AC2.2kw	470
WRHW4004	4000	300	1400	1200 x 2000	900 x 2000	45-50	380v/50HZ, AC2.2kw	490
WRHW4005	4000	300	1400	1000 x 2200	900 x 2000	45-50	380v/50HZ, AC2.2kw	480
WRHW4006	4000	300	1400	1200 x 2200	900 x 2000	45-50	380v/50HZ, AC2.2kw	505
WRHW4007	4000	300	1400	1500 x 1700	1200 x 1600	45-50	380v/50HZ, AC2.2kw	420
WRHW4008	4000	300	1400	1800 x 2200	1500 x 2000	45-50	380v/50HZ, AC2.2kw	540



All our products have a full 12 months ON SITE parts & labour warranty

12 MONTHS WARRANTY

Drum Handling

WARRIOR Drum Handling - DrumPorter

Easy to use lifts the drum hydraulically off the floor for transportation and smoothly lowers it via a spring return knob. The simple but very effective drum porter WRDT250 makes light work when moving 210 Litre Steel Drums around.

- ▶ Light, highly manoeuvrable & easy to use
- ▶ Manual hydraulic operation lifted by a hand operated pump unit
- ▶ Infinitely controlled "dead man" hand release wheel
- ▶ High push/pull handle bar
- ▶ Fitted with overload valve & parking brake
- ▶ Polyurethane tyres & swivel wheels

MODEL	WRDT250
Brand	Warrior
Lifting Height	345mm
Lifting per Stroke	22mm
Max Drum Diameter	572mm
Max Drum Length	915mm
Max. Height in Lowered Position	1000mm
Max. Height in Raised Position	1215mm
Length	810mm
Width	800mm
Net Weight	42kg

WARRIOR CE



weigh scale option

WARRIOR Drum Porter with Wide Straddle

The **WARRIOR** WRDTW250 has a wide straddle to enable the unit to lift 210 Litre Drums off pallets 800mm wide i.e. Europallets. The unit is exceptionally easy to operate, gliding along on large polyurethane wheels. Fitted with parking brake.

- ▶ Light, highly manoeuvrable & easy to use
- ▶ Manual hydraulic operation lifted by a hand operated pump unit
- ▶ Infinitely controlled "dead man" hand release wheel
- ▶ High push/pull handle bar
- ▶ Fitted with overload valve & parking brake
- ▶ Polyurethane tyres & swivel wheels

MODEL	WRDTW250
Brand	Warrior
Capacity	250kg
Lifting Height	345mm
Lifting per Stroke	22mm
Max Drum Diameter	572mm
Inside Straddle	850mm
Outside O/A Straddle	1015mm
Net Weight	45kg



WARRIOR Drum Porter Override

The **WARRIOR** DRUM PORTER Override WRDTR250 has a wide straddle and a cantilevered frame which allows it to pass over a 800mm max width pallet allowing drums to be manoeuvred both on and off with ease. The unit is exceptionally easy to operate, gliding along on large polyurethane wheels. Having a combination of wide straddle and cantilevered chassis also enables the WRDTR250 to lift drums off corners of spillage containment units.

- ▶ Light, highly manoeuvrable & easy to use - "rides over" an 800mm wide pallet
- ▶ Manual hydraulic operation lifted by a hand operated pump unit
- ▶ Infinitely controlled "dead man" hand release wheel
- ▶ High push/pull handle bar
- ▶ Fitted with overload valve & total stop brakes
- ▶ Polyurethane tyres & swivel wheels

MODEL	WRDTR250
Brand	Warrior
Capacity	250kg
Lift Height	250mm
Max Drum Height	1180mm
Min Drum Height	910mm
Drum Diameter	572mm
Inside Straddle	850mm
Outside O/A Straddle	980mm
Net Weight	50kg



Drum Handling

The Handling Equipment Shop

The premier name in materials handling...

WARRIOR Drum Porter plus

WARRIOR Drum Porter plus will handle 140 or 210 Litre drums on and off bund pallets as well as regular pallets.

MODEL	WRDTF450
Brand	Warrior
Lifting Capacity	450kg
Lifting Height	500mm
Lifting per Stroke	12mm
Max Drum Diameter	572mm
Max Drum Length	915mm
Max. Height in Lowered Position	1250mm
Max. height in Raised Position	1380mm
Length	900mm
Width	1020mm
Net Weight	165kg

WARRIOR CE



WARRIOR WRHJ365 Hydraulic Barrel Caddy

- ▶ CE marked
- ▶ One person can operate easily
- ▶ Only suitable for carrying and moving – not for tilting
- ▶ Lifting after grabbing fasten when operating

Model	WRHJ365
Brand	Warrior
Capacity	365kg
Acceptable Drum Style	210 litre
Maximum Height of Arm	390mm
Minimum Height of Arm	270mm
Radius of Arm	290mm
Drum Suitability	Steel
Oversize (l x w)	1022mm x 722mm
Net Weight	53kg



WARRIOR Drum Caddy

WARRIOR

Heavy duty, highly manoeuvrable & easy to use.
Can handle 140 Litre or 210 Litre steel and/or plastic drums.
Removal handle used to tilt drums for positioning and doubles up as a bung.

WARRIOR CE

MODEL	WRDC500
Brand	Warrior
Lifting Capacity	500kg
Drum Size	210 litre
Overall Size	950 x 570 x 750mm
Net Weight	17kg



All our products have a full 12 months ON SITE parts & labour warranty

12 MONTHS WARRANTY

Drum Handling

WARRIOR Fork Mounted Drum Tippler

- ▶ Suitable for 210 litre steel drums
- ▶ For tipping, pouring, etc
- ▶ Converts fork truck into a drum handler
- ▶ 10mm pull-chain loop allowing control drum driver's seat
- ▶ 30:1 ratio gear box preventing gravity roll

MODEL	WRHK285B
Brand	Warrior
Capacity	680kg
Fork Pockets	65 x 180mm
Fork Spread	575mm
Overall Width	980mm
Distance between Fork Pockets	620mm
Net Weight	97kg



WRHK285B

WARRIOR CE

WARRIOR WRHK285C Steel & Plastic Drum Tippler

- ▶ Suitable for steel and plastic drums
- ▶ For tipping, pouring, etc
- ▶ Converts fork truck into a drum handler
- ▶ Hand wheel and gearbox tipping
- ▶ 30:1 ratio gear box preventing gravity roll

MODEL	WRHK285C
Brand	Warrior
Capacity	300kg
Fork Pockets	55 x 150mm
Fork Spread	575mm
Overall Width	980mm
Distance between Fork Pockets	620mm
Net Weight	60kg



Plastic Drum



Steel Drum

WARRIOR CE

WARRIOR Drum Positioner

- ▶ Ideal for loading/unloading drums stored horizontally on drum racking & stands
- ▶ Suitable for loading drums on to vehicles
- ▶ Mechanically operated & can be utilised without the driver leaving the seat of the truck
- ▶ Hinged tines lock automatically when lowered to ground in horizontal position
- ▶ For manipulating 210 Litre steel or L & XL ring drums from horizontal to vertical & vice versa
- ▶ Easy to learn operating technique with written instructions provided

MODEL	WRDR400
Brand	Warrior
Capacity	400kg
Max Fork Width x Depth	140 x 50mm
Fork Spread	575mm
Overall Size	1900 x 5690 x 655mm
Net Weight	75kg



Scan for Video



WRDR400



WARRIOR CE

Drum Handling

The Handling Equipment Shop

The premier name in materials handling...

WARRIOR Automatic Drum Clamps for Fork Lift Trucks

WARRIOR Automatic Drum Clamps fit quickly and easily onto the forks. They are secured via hand screws. Once fitted, the drum clamp will automatically pick up, transport and deposit drums without the driver needing to leave the truck.

The drums are held in position by using their own weight to tighten the arms. When deposited the arms of the clamp simply slide away from the drum.

Available for Steel 210 litre Drums in either single or double drum configuration and now the WRDG50 for Single Plastic Drums.



WRDG20



WRDG50 with plastic drum

- ▶ CE marked
- ▶ Fit quickly and easily on to forks
- ▶ Drums held in position by using their own weight to tighten the arms
- ▶ Arms slide away from the drum when deposited
- ▶ Driver doesn't need to leave truck as drum clamp automatically picks up/deposits drums
- ▶ Secured by hand screws

MODEL	WRDG10	WRDG20	WRDG40	WRDG50
Brand	Warrior	Warrior	Warrior	Warrior
Capacity	680kg	680kg	680kg	453kg
Fork Pockets	51 x 140	57 x 178	57 x 178	38 x 137
Pocket Length	610mm	610mm	610mm	610mm
Drum Suitability & Configuration	Single Steel Drum	Double Steel Drum	Adjustable, Steel/Plastic Drum	Adjustable, Single Poly Drum
Net Weight	54 kg	89 kg	56 kg	18 kg



WRDG10



WRDG40 for steel and XL plastic drums

WARRIOR CE

All our products have a full 12 months ON SITE parts & labour warranty

12 MONTHS WARRANTY

Drum Handling / Access

WARRIOR Drum Pincers

- ▶ All steel construction
- ▶ Works easily with overhead hoist or hook from forklift
- ▶ Easily moves/handles open or closed head loaded steel drums
- ▶ Allows quick, gentle loading into overpacks keeping drums upright during lift

MODEL	BRAND	CAPACITY	DRUM	NET WEIGHT
WRDL500A	Warrior	500kg	210 litre	5kg
WRDL500B	Warrior	500kg	210 litre	7.5kg

WARRIOR CE

WRDL500B

WRDL500A



WARRIOR Drum Shift 'n' Tip

- ▶ Capacity 365kg
- ▶ 210L steel or plastic drums
- ▶ Picks up standard 210 Litre steel drums and plastic drums
- ▶ Push into place, attach the girdle, lift, attach the steadier (plastic drums)
- ▶ Once lifted the operator can tilt and lock the drum for pouring

WARRIOR CE

WRHD365B



WARRIOR Drum Clamp

- ▶ Capacity 350kg
- ▶ 210 Litre Steel Drums
- ▶ Operates easily from crane or forklift hook
- ▶ Net weight 9.5kg

WRDL350



WARRIOR Forklift Maintenance Platform

- ▶ For overhead access and maintenance with safety
- ▶ Personnel guard to keep forklift at bay
- ▶ Spring loaded inward opening door with safety latch
- ▶ Slip resistant floor with drainage holes
- ▶ Portable & easy to assemble
- ▶ Folds away for storage
- ▶ Conforms to Health & Safety Guidance note issue 3 PM28 and GN48 standard

MODEL	Brand	CAPACITY	DECK SIZE	OVERALL HEIGHT	FORK SPREAD
WRNK30C	Warrior	300kg	1000 x 1000mm	2180mm	600/690mm

WARRIOR CE



Drum Handling

WARRIOR Drum Stacker

- ▶ CE Marked
- ▶ Easy to lift & Transport a 210 Litre steel drum
- ▶ Able to carry drum to the rack
- ▶ Compact & reliable mechanism system to fix on to drum
- ▶ Manually operated
- ▶ Allows stacking of drums up to a maximum height of 1200mm

WARRIOR CE

MODEL	WRDS350
Brand	Warrior
Capacity	350kg
Overall Lift Height (to underside 210ltr drum)	1200mm
Overall height	2000mm
Overall Width	1146mm
Overall Length	1100mm
Inside Straddle	950mm
Overall Leg Height	90mm
Net Weight	175kg

WRDS350

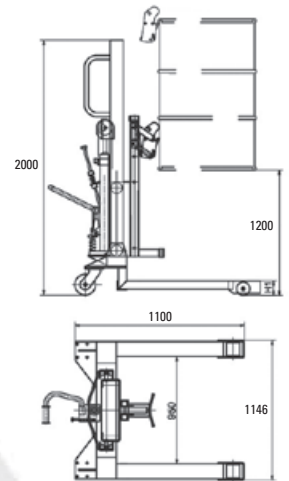

WARRIOR Drum Positioner (suitable for steel and plastic)

The WRDTPL45 is a versatile Drum Stacker, in particular because it allows the operator to handle steel/plastic drums, lifting, rotating and discharging the contents safely at height. Lift is performed hydraulically by handle/pedal combination and rotation is via a hand wheel. Drum rollback is prevented by 30:1 ratio transfer box.

- ▶ Auto overload protection fitted
- ▶ 210 Litre steel and plastic fibre supported & manual drum tilt
- ▶ Tandem liftchains
- ▶ Hydraulic pump action lift
- ▶ Easy to lift, transport & tilt a 45 gallon Drum
- ▶ Drum can be locked in horizontal or vertical position
- ▶ Manually operated
- ▶ Position for draining through a faucet

MODEL	WRDTPL45
Brand	Warrior
Capacity	450kg
Max. Lifting Height	1500mm
Acceptable Drum Type	Steel and plastic, fiber
Drum Tilting (electric/manual)	manual
With Weighing Scale (yes/no)	no
Load Rollers Size	Ø150 x 50mm
Steering Wheel Size	Ø150 x 50mm
Size Between Legs (Inner/Out)	630/810mm
Leg Length	770mm
Charger for Weighing Scale	6v
Overall Size (L x W x H)	1400 x 1000 x 2100mm
Net Weight	185kg



WRDTPL45

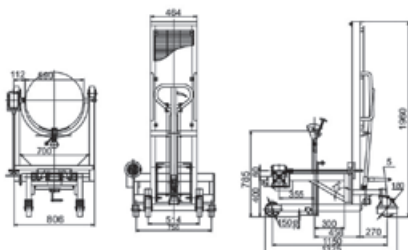

Scan for Video

WARRIOR CE

Drum Handling

WARRIOR WRLM800 Manual Type Drum Lifter

- ▶ CE marked
- ▶ Ideal for low level pouring and dumping operations
- ▶ Positive tilt lock on drum saddle to hold drum upright in transit
- ▶ Operator can manually tilt the drum to control pouring and can be rotated 360°
- ▶ Locks hold drum in horizontal position

MODEL	WRLM800
Brand	Warrior
Capacity	350kg
Acceptable Drum Style	210 Litre
Overall Dimensions (H x W x D)	991mm x 724mm x 196mm
Drum Suitability	Steel
Net Weight	20kg

WARRIOR CE



WARRIOR WRLF800 Forklift & Crane Mounted Drum Lifter

- ▶ CE marked
- ▶ Suitable for both forklift and crane usage

MODEL	WRLF800
Brand	Warrior
Capacity	350kg
Acceptable Drum Style	210 Litre
Drum Suitability	Steel & Plastic



WARRIOR WRLG800 Geared Type Drum Lifter

- ▶ CE marked
- ▶ Allows remote pouring operations
- ▶ Geared chain control & low effort feature enabling usability at any height
- ▶ Control chain can be locked to secure drum in any position during transit & dispensing

MODEL	WRLG800
Brand	Warrior
Capacity	350kg
Acceptable Drum Style	55 Gallon
Overall Dimensions (H x W x D)	991mm x 724mm x 196mm
Drum Suitability	Steel
Net Weight	38kg



Drum Handling

The Handling Equipment Shop

The premier name in materials handling...

WRPOTR-03/2400 WARRIOR 300kg Semi Electric Drum Tippler

- ▶ Rotating Gear Set of 360° with anti roll
- ▶ Lift by means of semi electric hydraulic pump unit
- ▶ Drum tipped by electro mechanical gearbox
- ▶ Lift by lever
- ▶ Tilt by corded remote control
- ▶ Clamp easy & light to use

MODEL	WRPOTR-03/2400
Brand	Warrior
Capacity	300 at 700mm Load Center kg
Minimum Lift Height from Top of Oil Tank	3450 mm
Minimum Lift Height from Botton of Oil Tank	2370 mm
Overall Truck Length	1350 mm
Overall Truck Width	915 mm
Minimum Mast Height	1980 mm
Turning Radius	1300 mm
Standard Oil Drum	Ø580 x 890 mm
Straddle Length	770 mm
Front & Rear Wheels	Ø180 x 50 mm
Battery	135V/12V
Charger	220V/12V-12A
Truck Weight	320 kg



Scan for Video

WRDT280 WARRIOR 280kg Counterbalanced Electric Drum Stacker



- ▶ Counterbalance design without front supporting leg
- ▶ Suitable for close top, steel drums and plastic drums
- ▶ Adjustable arc bracket to ensure handling drums upright
- ▶ Optional single (double) Gator Grip grabs

MODEL	WRDT280
Brand	Warrior
Capacity	280kg
Lift Height	1100mm
Lifting Speed	120mm/s
Overall Size	1300 x 810 x 1880mm
Wheel Size	Ø125 x 50mm
Turning Radius	1300mm
Pump Station Power	1.5Kw/h
Battery	12V/1200Ah
Net Weight	270kg

All our products have a full 12 months ON SITE parts & labour warranty

12 MONTHS WARRANTY

Forklift Truck Attachments

WARRIOR Fork Extensions

N.B. We recommend you check with manufacturer of the forklift truck its capabilities when lifting at an extended load centre.

- ▶ CE marked
- ▶ Simple & effective way of lengthening forks to handle longer loads safely
- ▶ Manufactured from heavy duty steel channel and will fit on to forks up to 50mm thick
- ▶ Steel retainers prevent forks from sliding off
- ▶ Fork extensions should not exceed the length of the fork they are fitted to by 40%
- ▶ Supplied as a matched pair

The **WARRIOR** range of fork extensions are a simple but effective way of lengthening your forks to handle longer loads safely without damaging the load. Manufactured from heavy duty steel channel they will fit on to forks up to 50mm thick. Steel retainers prevent the forks from sliding off. We recommend that you check with the manufacturer of your lift truck its capabilities when lifting at a greater load centre. Fork extensions should not exceed the length of fork to which they are fitted by more than 40%.

MODEL	Brand	Extension Length mm	Suit fork width mm	Weight per pair kg
WREX604	Warrior	1525	100	44
WREX605	Warrior	1525	125	49
WREX724	Warrior	1830	100	53
WREX725	Warrior	1830	125	59
WREX726	Warrior	1830	150	64
WREX824	Warrior	2085	100	60
WREX825	Warrior	2085	125	67
WREX826	Warrior	2085	150	70
WREX964	Warrior	2435	100	70
WREX965	Warrior	2435	125	79
WREX966	Warrior	2435	150	85



WARRIOR CE

WARRIOR Telescopic Fork Mounted Jib



WRTL01



three angles: 0°, 13°, 26°



WARRIOR CE

- ▶ CE marked
- ▶ One Swivel Hook, Bow
- ▶ Shackle & Rigid Hook
- ▶ Retention Chain
- ▶ 13 Jib Positions
- ▶ Converts the Forklift into a Mobile Crane

MODEL	WRTL01														
Positions	A	B	C	D	E	F	G	H	I	J	K	L	M	N	
Capacity	0°	740mm	969	1190	1427	1656	1885	2114	1352	2581	2810	3039	3268	3497	3726
		3000kg	2291	1853	1556	1341	1178	1050	944	860	790	730	679	635	596
13°		718mm	942	1165	1389	1612	1836	2060	2292	2516	2739	2963	3186	3410	3633
		3092kg	2357	1906	1598	1377	1209	1078	969	882	811	749	697	651	611
26°		690mm	897	1105	1312	1520	1727	1935	2150	2358	2566	2772	2980	3188	3305
		3217kg	2475	2009	1692	1460	1285	1147	1032	941	865	801	745	696	654
Net Weight	(kg)	240													

WARRIOR Fork Adapter Lifting Beam

- ▶ CE marked
- ▶ Swivel Hook
- ▶ Box Shackle
- ▶ Manufactured from Heavy Duty Steel Section
- ▶ Effective way of Converting a Forklift Truck into a Mobile Counterbalanced Crane

MODEL	WRMK25
Brand	Warrior
Capacity	2500kg
Max Fork Section	160 x 60mm

N.B. Please check with the manufacturer of your forklift truck its capabilities when lifting at an extended load centre.

WARRIOR CE



Skates

WARRIOR Skates

- ▶ CE marked
- ▶ Nylon rollers with sealed bearings
- ▶ Rubber anti slip top
- ▶ Single fixed skates
- ▶ Compact
- ▶ Rugged



Fixed Skates

MODEL	WRSKF30	WRSKF60
Brand	Warrior	Warrior
Capacity	3000kg	6000kg
No: of Rollers	4	6
No: of Axles	2	3
Roller Size	85mm x 85mm	85mm x 85mm
Skate Dimension (L x W x H) mm	330 x 220 x 100	265 x 198 x 100
Net Weight	9.5kg	12kg

- ▶ CE marked
- ▶ 4 x Roller (Caterpillar) Skates
- ▶ 2 x Rubber Top Turntables
- ▶ 2 x Pulling Handles
- ▶ 2 x Adjustable Tie Bards
- ▶ 1 x Storage Box on Wheels



Skate Kits WARRIOR CE

MODEL	WRSK20	WRSK30
Brand	Warrior	Warrior
Capacity	20000kg	30000kg
Length Support	120mm	120mm
Width Support	120mm	120mm
Total Height	108mm	117mm
Swivel Top	Ø130	Ø150
Weight	50kg	58kg

- ▶ CE marked
- ▶ Nylon Steel Rollers with
- ▶ Sealed Bearings
- ▶ Rubber Anti Slip Top
- ▶ Compact
- ▶ Rugged
- ▶ Pulling/Towing Handle



Steerable Skates

Incorporating a 1m drawbar and a swivelling platform.

MODEL	WRSKS30	WRSKS60	WRSKS120
Brand	Warrior	Warrior	Warrior
Capacity	3000kg	6000kg	12000kg
No: of Rollers	4 nylon	8 nylon	8 nylon
Roller Size	85mm x 90mm	85mm x 90mm	83mm x 85mm
Skate Dimension (L x W x H) mm	310 x 255 x 105	630 x 400 x 115	630 x 400 x 115
Weight	15kg	50kg	66kg

- ▶ CE marked
- ▶ Nylon or Steel Rollers with
- ▶ Sealed Bearings
- ▶ Rubber Anti Slip Top
- ▶ Compact & Adjustable
- ▶ Rugged
- ▶ Sold as Pair with Tie Bands

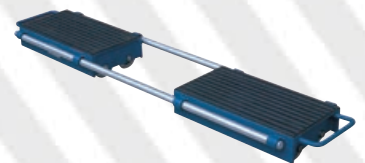

Adjustable Skates

Adjustable skates are actually 2 skates which are connected by 2 steel rods making 1 skate adjustable from 500mm to 1400mm (SKA60) 720mm to 1500mm (SKA120, SKA240).

Model	WRSKA60	WRSK120	WRSKA240
Brand	Warrior	Warrior	Warrior
Capacity	6000kg	12000kg	24000kg
No: of Rollers	8 nylon	12 nylon	16 steel
Skate Dimension (L x W x H) mm	300 x 250 x 115	360 x 220 x 115	360 x 220 x 115
Weight	30kg	38kg	65kg

Sack Trucks

WARRIOR Heavy Duty Sack Trucks

WARRIOR Heavy Duty Sack trucks are tough and durable. Heavy gauge steel with robust blue powder coating and mounted on rugged pneumatic tyres. Hand guards as standard. A selection of capacities and toe plates to suit. WRHT200, WRHT250, WRHT300

- ▶ CE marked
- ▶ Ideal for heavier applications such as shops, stores, small warehouses & delivery vehicles
- ▶ Made from heavy gauge steel
- ▶ Robust blue power coating
- ▶ Mounted on rugged pneumatic tyres
- ▶ Standard hand guard

MODEL	WRHT200	WRHT250	WRHT300
Warrior	Warrior	Warrior	Warrior
Capacity	200kg	250kg	300kg
Overall Height	1170mm	1175mm	1170mm
Overall Width	500mm	480mm	580mm
Foot Plate Length	235mm	235mm	200mm
Foot Plate Width	305mm	305mm	400mm
Wheel Type	Pneumatic	Pneumatic	Pneumatic
Wheel Diameter (L x W)	260mm x 85mm	260mm x 85mm	260mm x 85mm
Net Weight	14kg	14.5kg	17kg



WRHT200



WRHT250



WRHT300

WARRIOR CE

Sack Trucks

The Handling Equipment Shop

The premier name in materials handling...

WARRIOR Professional Heavy Duty Sack Trucks

WARRIOR Professional Heavy Duty Sack Trucks are extremely rugged and durable. Heavy duty tubular steel construction with thick welded toe plate. Powder coated scratch resistant blue RAL5007. Guarded hand grips, solid and pneumatic tyres on synthetic hubs with roller bearings. A selection of capacities and toe plates to suit. WRHT1125, WRHT1116, WRHT1216, WRHT1115, WRHT1116L, WRHT1110L

- ▶ CE marked
- ▶ Ideal for heavier applications, i.e. shops, stores, delivery vehicles & warehouses
- ▶ Rugged & durable
- ▶ Heavy duty tubular steel construction with thick welded toe plate
- ▶ Guarded hand grips
- ▶ Mounted on pneumatic tyres
- ▶ Powder coated scratch resistant blue RAL5007

MODEL	WRHT1125	WRHT1116	WRHT1216	WRHT1115	WRHT1116L	WRHT1110L
Capacity	200kg	250kg	350kg	250kg	250kg	200kg
Overall Height	1100mm	1150mm	1150mm	1150mm	1150mm	1130mm
Overall Width	500mm	520mm	560mm	570mm	560mm	430mm
Foot Plate Length	250mm	300mm	300mm	160mm	280mm	210mm
Foot Plate Width	320mm	480mm	480mm	400mm	480mm	320mm
Wheel Type	Solid	Solid	Solid	Solid	Pneumatic	Pneumatic
Wheel Diameter mm (l x w)	250 x 65	250 x 65	250 x 65	250 x 65	260 x 85	260 x 85
Weight	14kg	17.5kg	21kg	14.5kg	15.5kg	14kg



WRHT1125



WRHT1115



WRHT1216

WARRIOR CE

All our products have a full 12 months ON SITE parts & labour warranty

12 MONTHS WARRANTY

WARRIOR Stair Climber & WARRIOR Lite 2 Way Hand Truck

WARRIOR Stair climber is an ideal general purpose sack truck with the added bonus of star wheels to allow stair climbing. 200kg capacity and narrow enough to pass through a standard single doorway.

MODEL	WRHTS1325
Brand	Warrior
Capacity kg	200
Overall Height mm	1200
Overall Width mm	500
Foot Plate Length mm	200
Foot Plate Width mm	320
Wheel Type	Solid
Wheel Dia x w	160 x 40
Weight kg	14

- ▶ CE marked
- ▶ Ideal for warehouses, shopping centres and logistics
- ▶ All inclined sack truck and flat platform truck all in one
- ▶ Robust blue power coating
- ▶ Mounted on pneumatic tyres
- ▶ Guarded hand grips



WRHT1325

WARRIOR CE

WARRIOR 3 in 1 Heavy Duty Folding Sack Truck

A superb workhorse for most handling requirements. Sack truck, inclined sack truck and flat platform truck all in one! Quickly switches modes. Powder coated in blue with a quality finish and feel. WRHT1824

MODEL	WRHT1824
Brand	Warrior
Capacity kg	250
Overall Height mm	1280
Overall Width mm	480
Foot Plate Length mm	310
Foot Plate Width mm	420
Wheel Type	Pneumatic
Wheel Dia x w	260 x 85
Weight kg	14.5

- ▶ CE marked
- ▶ Ideal for warehouses, shopping centres and logistics
- ▶ All inclined sack truck and flat platform truck all in one
- ▶ Robust blue power coating
- ▶ Solid rubber tyres

WARRIOR CE



Sack Trucks

WARRIOR Professional Folding Platform Truck

WARRIOR Professional WRTD1150 Folding Platform truck ideal for all aspects of logistics. Rugged but lightweight heavy duty design and fitted with non-marking rubber tyred wheels and castors. **WARRIOR** super lightweight WRBP150 aluminium folding and extendable platform truck. Original design offering extending platform for more flexible application.

- ▶ CE marked
- ▶ Ideal for all aspects of logistics
- ▶ Rugged but lightweight heavy duty design
- ▶ Fitted with non-marking rubber tyred wheels & castors

MODEL	WRTD1150	WRBP150	WRNP150
Brand	Warrior	Warrior	Warrior
Capacity kg	150	150	150
Platform Dimensions	740 x 480mm	500 x 420mm	750 x 470mm
Ext Platform L x W		710 x 420mm	
Handle Height	860mm		
Wheel Type	NM Rubber	Rubber	Rubber
Wheel Dia	Ø100	Ø100	Ø100
Weight kg	12.5	8	9



WRTD1150



WRNP150



WRBP150



WARRIOR CE

All our products have a full 12 months ON SITE parts & labour warranty

12 MONTHS WARRANTY

Platform Trucks

WARRIOR Mesh Side Platform Trucks



WRZ50A



WRZ50C



WRZ50G



WRZ50L



WRZ50E

WRZ50E

- ▶ CE marked
- ▶ 2 swivel braked castors
- ▶ Steel tubular frames supporting sides, end & deck
- ▶ 2 deck sizes available
- ▶ Self assembly required

MODEL	BRAND	CAPACITY	PLATFORMS DIMENSIONS	OVERALL SIZE	SIDES	WEIGHTS kg
WRZ50A	Warrior	500kg	1000 x 700	1200 x 700 x 1170	3 Full Sides	44
WRZ50B	Warrior	500kg	1200 x 800	1400 x 800 x 1170	3 Full Sides	49
WRZ50C	Warrior	500kg	1000 x 700	1200 x 700 x 1170	4 Full Sides	45
WRZ50D	Warrior	500kg	1200 x 800	1400 x 800 x 1170	4 Full Sides	50
WRZ50E	Warrior	500kg	1000 x 700	1100 x 700 x 1170	1 Full End	35
WRZ50F	Warrior	500kg	1200 x 800	1300 x 800 x 1170	1 Full End	38
WRZ50G	Warrior	500kg	1000 x 700	1100 x 700 x 1170	4 Semi Sides	40
WRZ50H	Warrior	500kg	1200 x 800	1300 x 800 x 1170	4 Semi Sides	43
WRZ50K	Warrior	500kg	1000 x 700	1200 x 700 x 1170	2 Full Ends	41
WRZ50L	Warrior	500kg	1200 x 800	1400 x 800 x 1170	2 Full Ends	44
WRZ50M	Warrior	500kg	1000 x 700	1000 x 930 x 1170	2 Full Sides	43
WRZ50N	Warrior	500kg	1200 x 1030	1200 x 1030 x 1170	2 Full Sides	46

WARRIOR CE

Platform Trucks

WARRIOR Heavy Duty Aluminium Platform Trucks

- ▶ CE marked
- ▶ Light & durable
- ▶ Heavy duty wheels & castors
- ▶ 2 swivel castors; fitted with optional 2nd handle
- ▶ Self assembly required



Fitted with optional 2nd handle

MODEL	BRAND	CAPACITY (kg)	PLATFORMS L x W (mm)	PLATFORMS HEIGHT (mm)	HANDLE HEIGHT (mm)	WHEEL DIA (mm)	WHEEL TYPE	WEIGHT kg
WRY2436A	Warrior	900kg	915 x 610	236	910	125	Polyurethane	20
WRY2448A	Warrior	900kg	1220 x 610	236	910	125	Polyurethane	25
WRY3048A	Warrior	900kg	1220 x 760	236	910	125	Polyurethane	28
WRY3060A	Warrior	900kg	1520 x 760	236	910	125	Polyurethane	33
WRY3672A	Warrior	900kg	1830 x 815	236	910	125	Polyurethane	38
WRX2436A	Warrior	1350kg	915 x 610	260	940	150	Polyurethane	21
WRX2448A	Warrior	1350kg	1220 x 610	260	940	150	Polyurethane	26
WRX3048A	Warrior	1350kg	1220 x 760	260	940	150	Polyurethane	29
WRX3060A	Warrior	1100kg	1520 x 760	260	940	150	Polyurethane	34
WRX3672A	Warrior	1100kg	1830 x 815	260	940	150	Polyurethane	39
WRZ2436A	Warrior	550kg	915 x 610	300	980	200	Pneumatic	24
WRZ2448A	Warrior	550kg	1220 x 610	300	980	200	Pneumatic	29
WRZ3048A	Warrior	550kg	1220 x 760	300	980	200	Pneumatic	32
WRZ3060A	Warrior	550kg	1520 x 760	300	980	200	Pneumatic	37
WRZ3672A	Warrior	550kg	1830 x 815	300	980	200	Pneumatic	42

WARRIOR Heavy Duty Steel Platform Trucks

- ▶ CE marked
- ▶ Durable 14 guage steel
- ▶ Heavy duty wheels & castors
- ▶ 2 swivel castors
- ▶ Self assembly required



MODEL	BRAND	CAPACITY (kg)	PLATFORMS L x W (mm)	PLATFORMS HEIGHT (mm)	HANDLE HEIGHT (mm)	WHEEL DIA (mm)	WHEEL TYPE	WEIGHT kg
WRY2436	Warrior	450kg	915 x 610	215	840	125	Polyurethane	30
WRY2448	Warrior	450kg	1220 x 610	215	840	125	Polyurethane	35
WRY3048	Warrior	450kg	1220 x 760	215	840	125	Polyurethane	40
WRY3060	Warrior	450kg	1520 x 760	215	840	125	Polyurethane	45
WRY3672	Warrior	450kg	1830 x 815	215	840	125	Polyurethane	56
WRX2436	Warrior	900kg	915 x 610	240	865	150	Polyurethane	32
WRX2448	Warrior	900kg	1220 x 610	240	865	150	Polyurethane	37
WRX3048	Warrior	900kg	1220 x 760	240	865	150	Polyurethane	40
WRX3060	Warrior	900kg	1520 x 760	240	865	150	Polyurethane	46
WRX3672	Warrior	900kg	1830 x 815	240	865	150	Polyurethane	58
WRZ2436	Warrior	540kg	915 x 610	280	905	200	Pneumatic	39
WRZ2448	Warrior	540kg	1220 x 610	280	905	200	Pneumatic	44
WRZ3048	Warrior	540kg	1220 x 760	280	905	200	Pneumatic	48
WRZ3060	Warrior	540kg	1520 x 760	280	905	200	Pneumatic	54
WRZ3672	Warrior	540kg	1830 x 815	280	905	200	Pneumatic	65

All our products have a full 12 months ON SITE parts & labour warranty

12 MONTHS WARRANTY

Load Movers

WARRIOR Safelift

The **WARRIOR** Safelift is the ultimate equipment for alleviating problem on site handling issues. It allows professional transportation of heavy and awkward loads like safes, cabinets, switchgear, vending machines, and machinery weighing up to 4500kg.

The **WARRIOR** Safelift is supplied in pairs (one for each end of the load) and when strapped together around a load (using the 5m securing straps supplied) can lift the load to a max of 310mm (model dependent) and then be manually propelled around corridors, around corners into lifts etc...

They can be easily transported around due to their low individual weight. Units are finished in orange powder coating and zinc chromate. Mounted on non marking polyurethane swivel castors all round.



WARRIOR CE



- ▶ Lightweight individual Safelift units
- ▶ Ideal for transportation of heavy and awkward loads
- ▶ Professional moving of safes, cabinets, switchgear, vending machines, furniture, etc
- ▶ Manually propelled
- ▶ Multi directional
- ▶ Rubber coated lifting toes
- ▶ Polyurethane swivel castors

MODEL WR180B	WARRIOR SAFELIFT®
Brand	Warrior
Load Capability (per pair)	1800kg
Lifting Height	250 mm
Lifting Toe Plate (W x D)	600 x 60 mm
Wheel Diameter	150 mm
Overall Size (L x W x H)	680 x 420 x 1070 mm
Net Weight	86 kg

- ▶ For professional transport of heavyweight items
- ▶ Ideal for delivery, removal, maintenance and assembly applications
- ▶ For switch cupboards, safes, containers and machinery
- ▶ Sold in one set only: Including two transport unit with hydraulic lift and built-in securing straps. Strap length 5 meters. Steering handles for direct wheel control. Load is easily transported and exactly positioned.
- ▶ Operation: Position lifting plates underneath item to be moved, Tension securing straps. Lift item on both sides to equal height and move.
- ▶ Technical specification: Support rails with protective covering. Powder coated finish. Heavy duty wheels with ball bearings. Non-marking polyurethane wheel suitable for carpeted flooring

MODEL	WR270A	WR270B	WR360A	WR450A
Brand	Warrior	Warrior	Warrior	Warrior
Capacity	2700kg	2700kg	3600kg	4500kg
Lifting Height	150mm	305mm	160mm	160mm
Wheel	Dia. 150mm	Dia. 150mm	Dia. 200mm	Dia. 200mm
Overall Size	585 x 1050mm	585 x 1050mm	585 x 1100mm	610 x 1210mm
Net Weight	148kg	164kg	182kg	218kg

Load Movers

The Handling Equipment Shop

The premier name in materials handling...

WARRIOR Folding Workshop Crane

- ▶ Heavy duty
- ▶ Double acting pump unit
- ▶ Heavy duty swivel hook with safety catch
- ▶ Pressure relief valve to prevent overloading
- ▶ Self standing on 4 wheels when folded

MODEL	WRHDFC10	WRSC2000
Brand	Warrior	Warrior
Capacity @ Setting 1	1000kg	2000kg
Capacity @ Setting 2	800kg	1700kg
Capacity @ Setting 3	700kg	1500kg
Overall Length	1630mm	1900mm
Overall Width	1120mm	1165mm
Max Hook Height	244mm	2705mm
Min Hook Height	Floor level	Floor level
O/A Supporting Height	80mm	205mm
Packing Size	1750 x 500 x 650mm	2000 x 630 x 680mm
Net Weight	115kg	165kg



The **WARRIOR** Crane is self standing and completely mobile when in the folded position

WARRIOR CE

All our products have a full 12 months ON SITE parts & labour warranty

12 MONTHS WARRANTY

Manual Cranes

WARRIOR Manual Counterbalanced Crane

The **WARRIOR** Heavy Duty Counterbalanced Workshop Crane is free standing with 5 variable capacity settings (maximum capacity available is 550kg) afforded by its 5 position telescopic jib and heavy duty swivel hook with safety catch.

Counterbalanced floor cranes are really useful in machine shops and other manufacturing environments where access to machinery is restricted by floor level objects.

- ▶ Heavy duty counterbalanced crane
- ▶ Up to 550kg capacity
- ▶ Double acting hand hydraulic pump unit
- ▶ Heavy duty swivel hook with safety catch
- ▶ Pressure relief valve to prevent overloading
- ▶ Extremely easy to manoeuvre
- ▶ 2900mm maximum lift height
- ▶ Floor level minimum hook height
- ▶ 5 variable capacity settings
- ▶ 5 position telescopic jib
- ▶ CE Marked
- ▶ Counterbalance allows total jib access - ideal when loading millers, lathes and other machine tools

NOTE THIS CRANE IS SUPPLIED COMPLETE WITH COUNTERBALANCE UNLIKE OTHERS ON THE MARKET WHERE YOU NEED TO ADD YOUR OWN!!

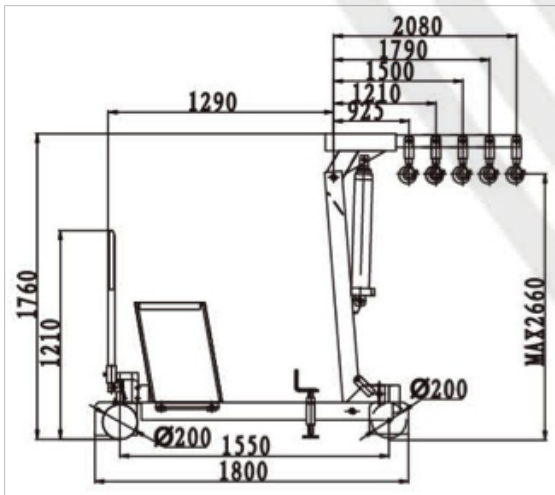

MODEL	WARRIOR WRTS8550
Capacity @ Minimum Jib	550kg
Capacity @ Jib position 2 -	500kg
Capacity @ Jib position 3 -	450kg
Capacity @ Jib position 4 -	400kg
Capacity @ Maximum Extent	350kg
Overall Length	2100mm
Overall Width	1050mm
Overall Height	1760mm
Overall Height Folded	870mm
Net Weight	500kg

Powered Cranes

WARRIOR Manual Counterbalanced Slewing Crane

- ▶ Supplied complete with counterbalance
- ▶ Versatile & innovative to allow accommodation of moulds, spare parts & machine tools
- ▶ 360° pivoting arm
- ▶ Light, double acting hand hydraulic pump unit
- ▶ Swivel hook & adjustable knob
- ▶ Block valve to prevent overloading
- ▶ Minimal foot print area to enable easy manoeuvring



MODEL	WRAA01M5
Brand	Warrior
Capacity	500kg
Capacity @ Full Lift Height	160kg @ 1360mm
Lowered Height	1800mm
Maximum Pressure	160 BAR
Tank Capacity	1 Litre
Cylinder Stroke/Diameter/Stem	470 x 60 x 40mm
Outreach with Standard Jib 1)	455mm long x 500kg capacity
2)	590mm long x 420kg capacity
3)	725mm long x 370kg capacity
4)	955mm long x 220kg capacity
Outreach with Extension Jib 1)	955mm long x 220kg capacity
2)	1090mm long x 200kg capacity
3)	1225mm long x 180kg capacity
4)	1360mm long x 160kg capacity

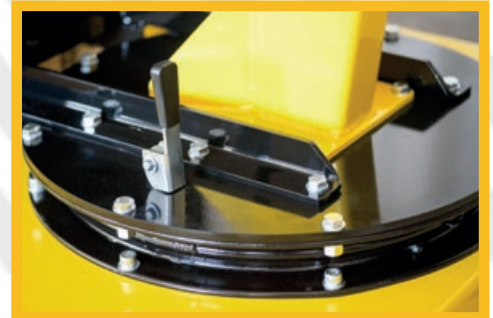
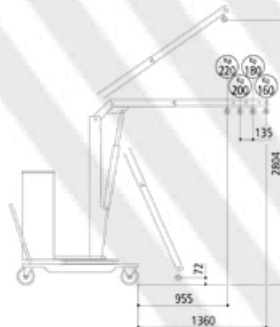
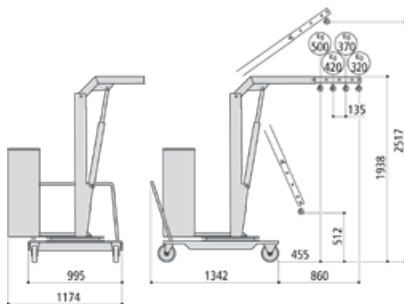

WARRIOR CE

Powered Cranes

WARRIOR Powered Counterbalanced Crane

The **WARRIOR** Pedestrian Controlled Powered Counterbalanced floor crane is an ideal machine to assist in the access of those hard to reach areas where traditional outrigger cranes cannot reach. The **WARRIOR** WRPDCB700 is a counterbalanced floor crane with added power for handling and transporting heavy loads up to 700kg.

This electric floor crane has a compact 763mm width and powered drive so it can be easily manoeuvred into position on congested sites. Ideal for handling industrial equipment, stacks of building materials and unitized glazing when fitted with a vacuum lifter, the **WARRIOR** WRPDCB700 has supportive struts on its base and can travel at a speed of up to 2.5km/h with a load.

With a convenient on-board battery charger, the **WARRIOR** WRPDCB700's powered boom can move up and down as well as telescoping in and out for precisely lifting loads from the ground up. This floor crane takes the strain out of lifting to a height of 3.3metres and has a maximum reach of 2.3 meters (at 200kg capacity).

On board battery charger with a powered boom that can move up/down and telescope in/out.

MODEL	WRPDCB700
Brand	Warrior
Capacity	700kg
Dimensions (l x w x h)	2000 x 763 x 1670mm
Maximum Hook Height	3300mm
Maximum Reach	2322mm
Boom Type (Hydraulic)	Manual Third Section
Battery	24V/70Ah
Maximum Speed with Load	2.5km/h

WARRIOR CE



Battery Powered Trucks

WARRIOR Battery Powered Forklift Truck



- ▶ Capacity 1500 - 3500kg
- ▶ Lift height up to 7m
- ▶ ZAPI AC/DC controllers
- ▶ Solid tyres sideshift
- ▶ Work lights
- ▶ Battery options
- ▶ Supplied with charger

Call for more details across all products

WARRIOR CE

Artison Battery Powered Forklift Truck

- ▶ Capacity 1500 - 3500kg
- ▶ Lift height up to 7m
- ▶ ZAPI AC controllers
- ▶ Solid tyres sideshift
- ▶ Work lights
- ▶ Battery options
- ▶ Supplied with charger

Call for more details across all products



Gas Powered Trucks

WARRIOR LPG Forklift Truck

- ▶ Capacity 1500 - 5000kg
- ▶ Lift height up to 7m
- ▶ Japanese Nissan Engine
- ▶ Solid tyres sideshift, solid lighting all standard
- ▶ Suspension seat

Call for more details across all products

WARRIOR CE



Artison LPG Forklift Truck

- ▶ Capacity 1500 - 5000kg
- ▶ Lift height up to 7m
- ▶ Japanese Nissan Engine
- ▶ Solid tyres sideshift, solid lighting all standard
- ▶ Suspension seat

Call for more details across all products



Diesel Powered Trucks

WARRIOR Diesel Forklift Truck

- ▶ Capacity 1500 - 5000kg
- ▶ Lift height up to 7m
- ▶ Yammer Engine
- ▶ Solid tyres sideshift, solid lighting all standard
- ▶ Suspension seat

Call for more details across all products

WARRIOR CE



Artison Diesel Forklift Truck

- ▶ Capacity 1500 - 5000kg
- ▶ Lift height up to 7m
- ▶ Yanmar engines
- ▶ Solid tyres sideshift, road lighting all standard
- ▶ Suspension seat

Call for more details across all products



The Handling Equipment Shop

All WARRIOR products are backed up with our No Nonsense after sales coverage.

We carry a comprehensive stock of parts for all models in our portfolio.

Our warranty is 12 months on site and where possible we use our own engineers to perform repairs and maintenance.

Enquire with your WARRIOR dealer for any service & maintenance requirements.

EUROPEAN
handling equipment



European Handling Equipment Ltd
Coronation Works, Providence Street,
Lye, Stourbridge DY9 8HN

Tel: 01384 423330 Fax: 01384 423332
email: enquiries@european-handling.com
website: www.european-handling.com



All our products have a full 12 months ON SITE parts & labour warranty



WARRIOR CE



The Handling Equipment Shop

All WARRIOR products are backed up with our No Nonsense after sales coverage.

We carry a comprehensive stock of parts for all models in our portfolio.

Our warranty is 12 months on site and where possible we use our own engineers to perform repairs and maintenance.

Enquire with your WARRIOR dealer for any service & maintenance requirements.



All our products have a full 12 months ON SITE parts & labour warranty



WARRIOR CE